

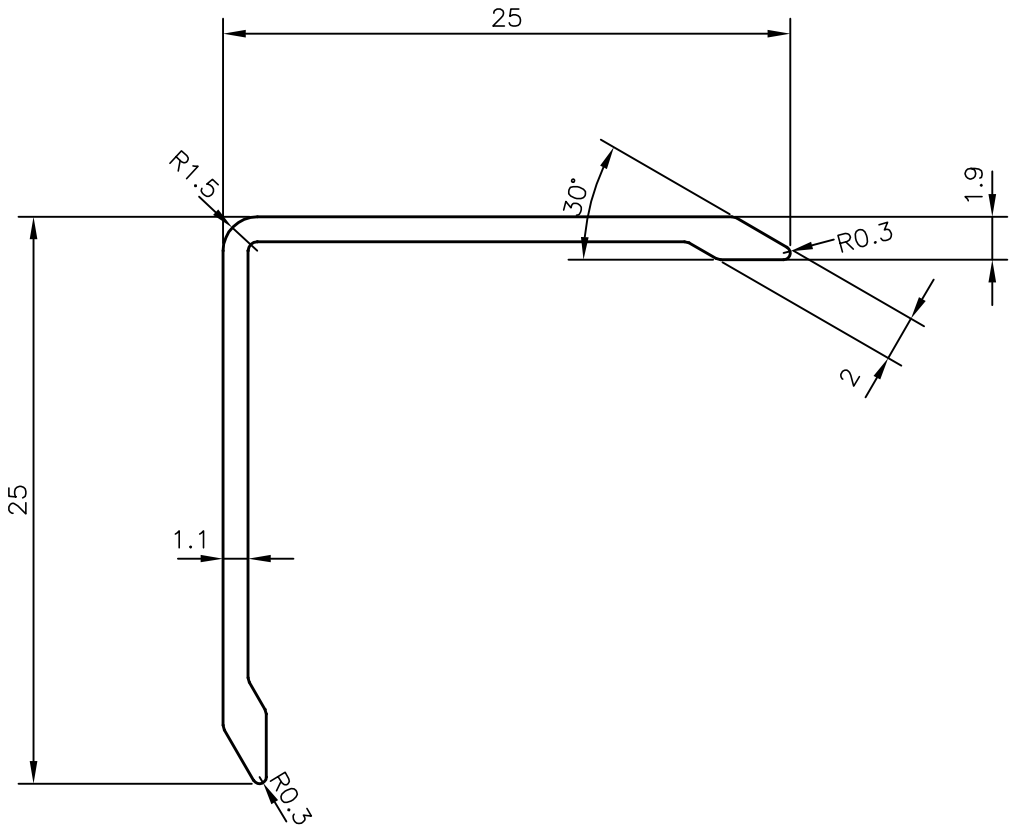

P-10831-1
X1482
34549
E0182

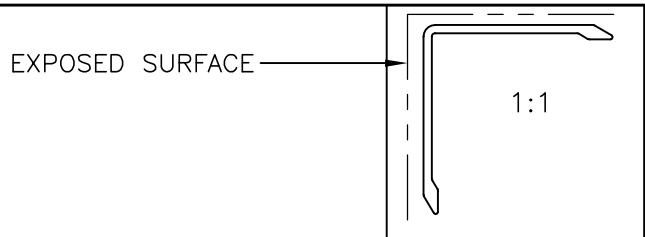

ISSUE-2 :- V GROOVE REMOVED
 WEIGHT ALSO CHANGED FROM 0.149 Kg/M TO 0.151 Kg/M

 SYMBOL OF QUALITY AN ISO 9001 COMPANY	JINDAL ALUMINIUM LTD. BANGALORE-560073 (INDIA)			NAME	DATE
		DRAWN	J.P.KAUSHIK	23-01-2012	
1. ALL DIMENSIONS ARE IN mm. 2. ROUND OFF ALL SHARP CORNERS WITH 0.40 mm. 3. TOLERANCES WILL BE AS PER IS:3965-1981 UNLESS OTHERWISE SPECIFIED		CHECKED			
		APPROVED	S.S.GARG	24-01-2012	
PARTY'S NAME SURFACES., BANGALORE		SCALE		3:1	
		AREA mm ²		55.962	
PARTY'S DRAWING No. AS PER SAMPLE		PERIMETER mm.		98.773	
		WEIGHT kg/m		0.151	
ALLOY & TEMPER HE9 WP		DRAWING No.	SECTION No.		
		P-10831-1	-		
DESCRIPTION MISC. ANGLE		X1482	X1482(ISSUE-2)		
		34549	34549		
		E0182	E0182		