

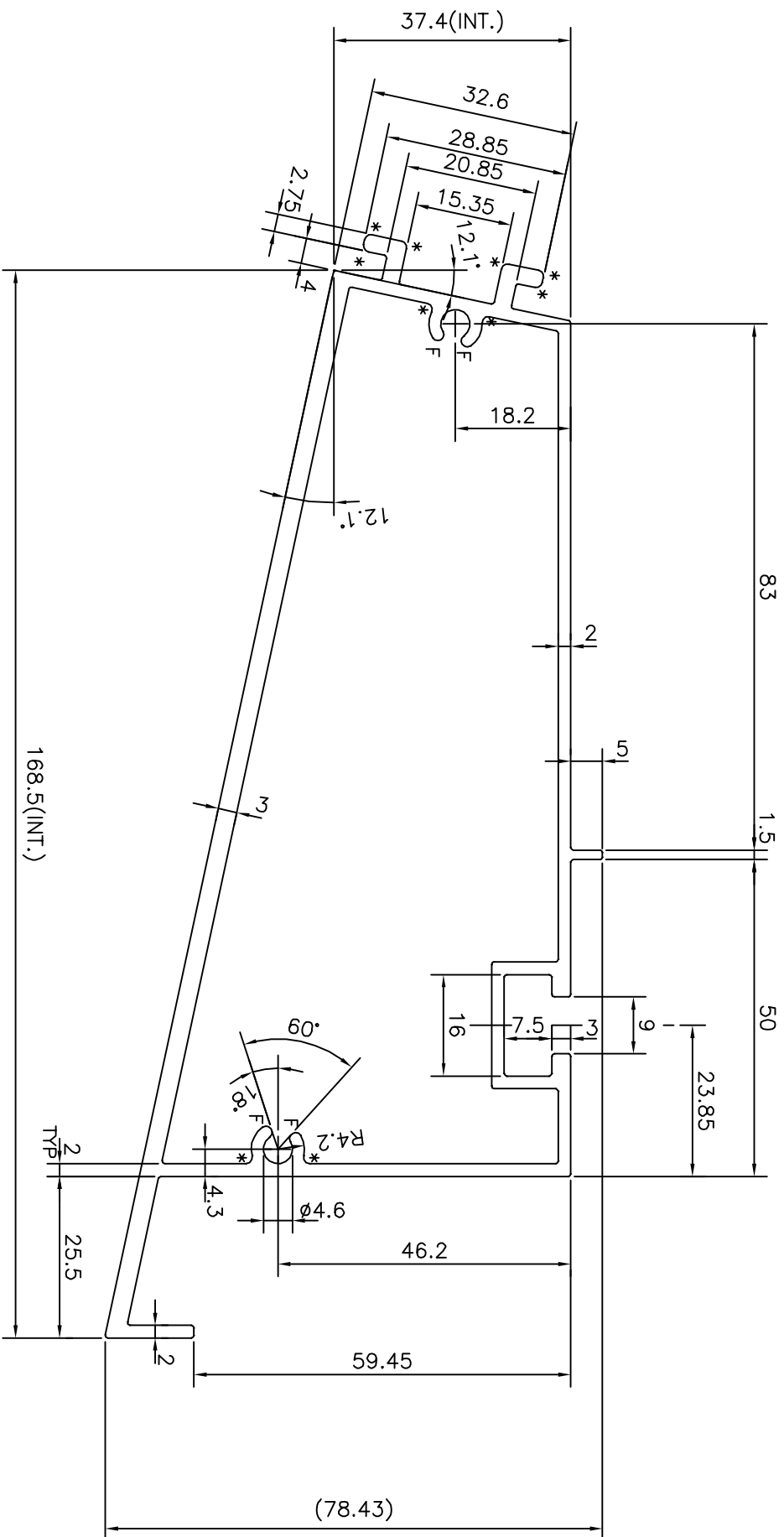

P-14223

E0229

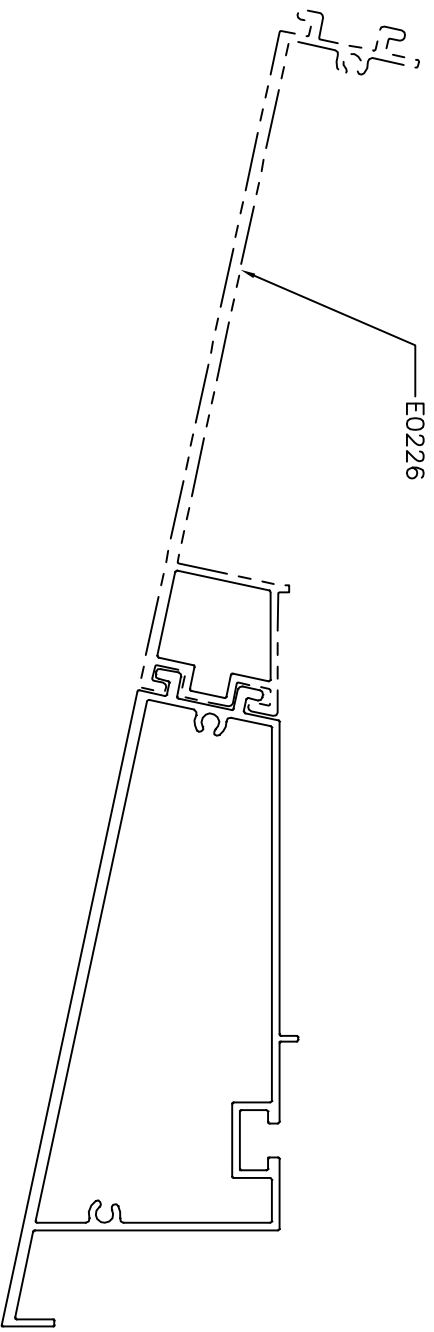

F = FULL RADIUS (4 PLACES)
 * = RADIUS 1.0 (10 PLACES)



 SYMBOL OF QUALITY AN ISO 9001 COMPANY		JINDAL ALUMINIUM LTD. BANGALORE-560073 (INDIA)	
1. ALL DIMENSIONS ARE IN mm. 2. ROUND OFF ALL SHARP CORNERS WITH 0.40 mm. 3. TOLERANCES WILL BE AS PER IS:6477-1983 UNLESS OTHERWISE SPECIFIED			
PARTY'S NAME		ALUFIT (INDIA) PVT. LTD., BANGALORE	
PARTY'S DRAWING No.		GD-E & AutocAD DRAWING	
ALLOY & TEMPER		6063 T6	
DESCRIPTION		ADOPTER-3	
DRAWN	NAME	DATE	
CHECKED	J.P.KAUSHIK	04-12-2014	
APPROVED	S.S.GARG	16-12-2014	
SCALE	1:1		
AREA	mm ²	1174.931	
PERIMETER	mm.	542.121	
WEIGHT	kg/m	3.172	
DRAWING No.	SECTION No.		
P-14223	-		
E0229	E0229		