

P-14144

E0263

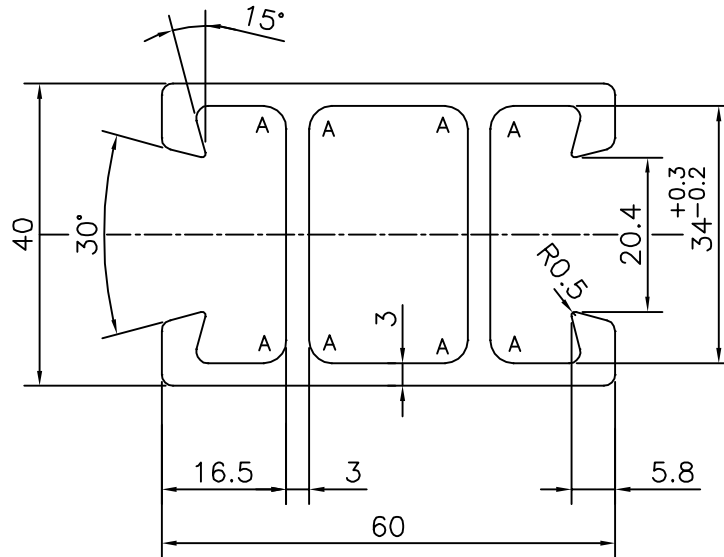

TOLERANCE CHART CD = CIRCUMSCRIBING CIRCLE

DIMENSION	CD≤100	100<CD≤200	200<CD≤300	300<CD≤500
UPTO 10mm	±0.25	±0.30	±0.35	±0.40
10.0 -25.0	±0.30	±0.40	±0.50	±0.60
25.0 -50.0	±0.50	±0.60	±0.80	±0.90
50.0 -100	±0.70	±0.90	±1.10	±1.30
100 - 150	-	±1.10	±1.30	±1.50
150 - 200	-	±1.3	±1.50	±1.80
200 - 300	-	-	±1.70	±2.10
300 - 450	-	-	-	±2.80

A = RADIUS 3 mm. (8 PLACES)  
X = RADIUS 1.5 mm. (12 PLACES)



SYMBOL OF QUALITY  
AN ISO 9001 COMPANY

**JINDAL ALUMINIUM LTD.**  
BANGALORE-560073 (INDIA)

	NAME	DATE
DRAWN	PARVESH	28-11-2014
CHECKED		
APPROVED	S.S.GARG	01-01-2015
SCALE		1:1
AREA mm <sup>2</sup>		702.021
PERIMETER mm.		308.503
WEIGHT kg/m		1.895
DRAWING No.		SECTION No.
P-14144		-
E0263		E0263

- ALL DIMENSIONS ARE IN mm.
- ROUND OFF ALL SHARP CORNERS WITH 1.50 mm.
- TOLERANCES WILL BE AS PER BS:EN-755-9 , UNLESS OTHERWISE SPECIFIED

PARTY'S NAME	WRIGHTBUS INDIA (ENG.) PVT. LTD., KANCHEEPURAM
PARTY'S DRAWING No.	AS PER AUTOCAD DRAWING-AUE-00001
ALLOY & TEMPER	6005 T6
DESCRIPTION	MISC. SECTION