

P-14149

E0268

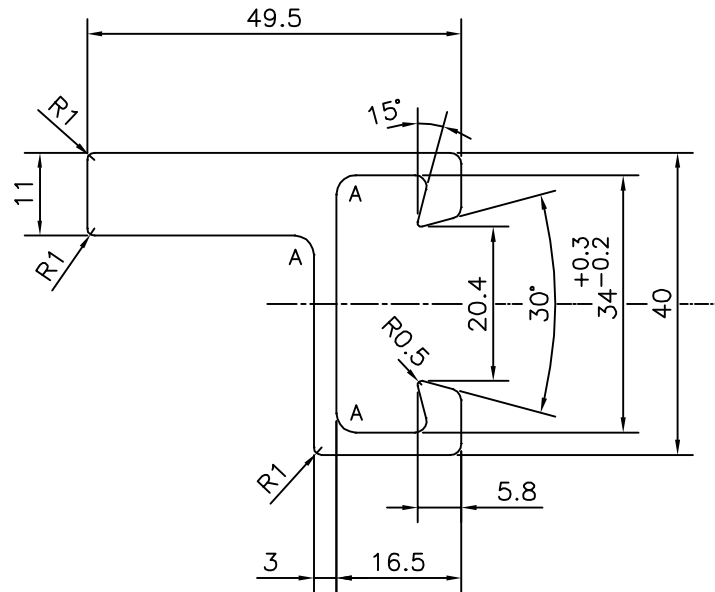

TOLERANCE CHART CD = CIRCUMSCRIBING CIRCLE

DIMENSION	CD ≤ 100	100 < CD ≤ 200	200 < CD ≤ 300	300 < CD ≤ 500
UPTO 10mm	±0.25	±0.30	±0.35	±0.40
10.0 - 25.0	±0.30	±0.40	±0.50	±0.60
25.0 - 50.0	±0.50	±0.60	±0.80	±0.90
50.0 - 100	±0.70	±0.90	±1.10	±1.30
100 - 150	-	±1.10	±1.30	±1.50
150 - 200	-	±1.3	±1.50	±1.80
200 - 300	-	-	±1.70	±2.10
300 - 450	-	-	-	±2.80

A = RADIUS 2.5 mm. (3 PLACES)



SYMBOL OF QUALITY
AN ISO 9001 COMPANY

JINDAL ALUMINIUM LTD.
BANGALORE-560073 (INDIA)

	NAME	DATE
DRAWN	PARVESH	28-11-2014
CHECKED		
APPROVED	S.S.GARG	01-01-2015
SCALE		1:1
AREA mm ²		613.665
PERIMETER mm.		231.32
WEIGHT kg/m		1.657
DRAWING No.	SECTION No.	
P-14149	-	
E0268	E0268	

- ALL DIMENSIONS ARE IN mm.
- ROUND OFF ALL SHARP CORNERS WITH 1.50 mm.
- TOLERANCES WILL BE AS PER BS:EN-755-9 , UNLESS OTHERWISE SPECIFIED

PARTY'S NAME	WRIGHTBUS INDIA (ENG.) PVT. LTD., KANCHEEPURAM
PARTY'S DRAWING No.	AS PER AUTOCAD DRAWING-AUE-00309
ALLOY & TEMPER	6082 T6
DESCRIPTION	MISC. SECTION