

P-14289-1

E0275

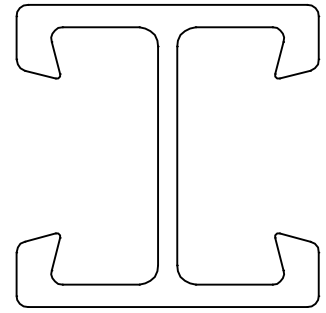

SCALE: - 1:1

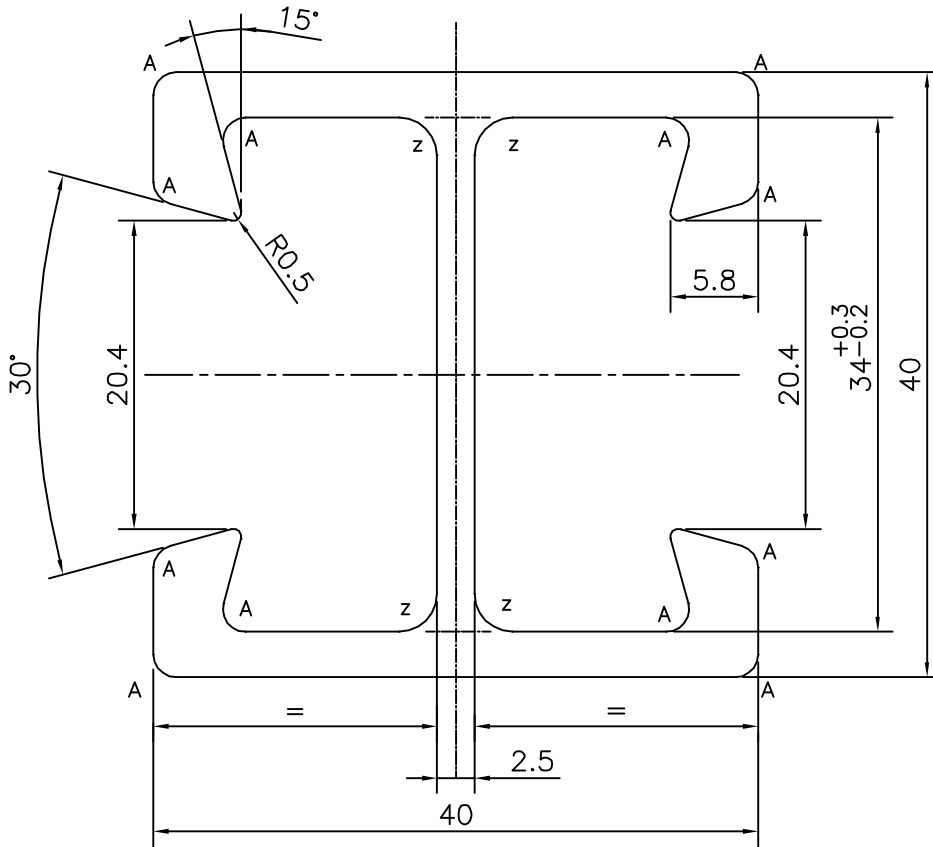

TOLERANCE CHART CD = CIRCUMSCRIBING CIRCLE

DIMENSION	CD ≤ 100	100 < CD ≤ 200	200 < CD ≤ 300	300 < CD ≤ 500
UPTO 10mm	±0.25	±0.30	±0.35	±0.40
10.0 - 25.0	±0.30	±0.40	±0.50	±0.60
25.0 - 50.0	±0.50	±0.60	±0.80	±0.90
50.0 - 100	±0.70	±0.90	±1.10	±1.30
100 - 150	-	±1.10	±1.30	±1.50
150 - 200	-	±1.3	±1.50	±1.80
200 - 300	-	-	±1.70	±2.10
300 - 450	-	-	-	±2.80

A = RADIUS 1.5 mm. (12 PLACES)  
 Z = RADIUS 2.5 mm. (4 PLACES)



SYMBOL OF QUALITY  
 AN ISO 9001 COMPANY

**JINDAL ALUMINIUM LTD.**  
 BANGALORE-560073 (INDIA)

	NAME	DATE
DRAWN	PARVESH	12-01-2015
CHECKED		
APPROVED	S.S.GARG	27-01-2015
SCALE		2:1
AREA mm <sup>2</sup>		452.935
PERIMETER mm.		278.361
WEIGHT kg/m		1.223
DRAWING No.	SECTION No.	
P-14289-1	-	
E0275	E0275	

- ALL DIMENSIONS ARE IN mm.
- ROUND OFF ALL SHARP CORNERS WITH 0.5 mm.
- TOLERANCES WILL BE AS PER BS:EN-755-9, UNLESS OTHERWISE SPECIFIED

PARTY'S NAME	WRIGHTBUS INDIA (ENG.) PVT. LTD., KANCHHEPURAM
PARTY'S DRAWING No.	AS PER AUTOCAD DRAWING-AUE-00128
ALLOY & TEMPER	6005 T6
DESCRIPTION	ECO SECTION