

P-14482

E0287

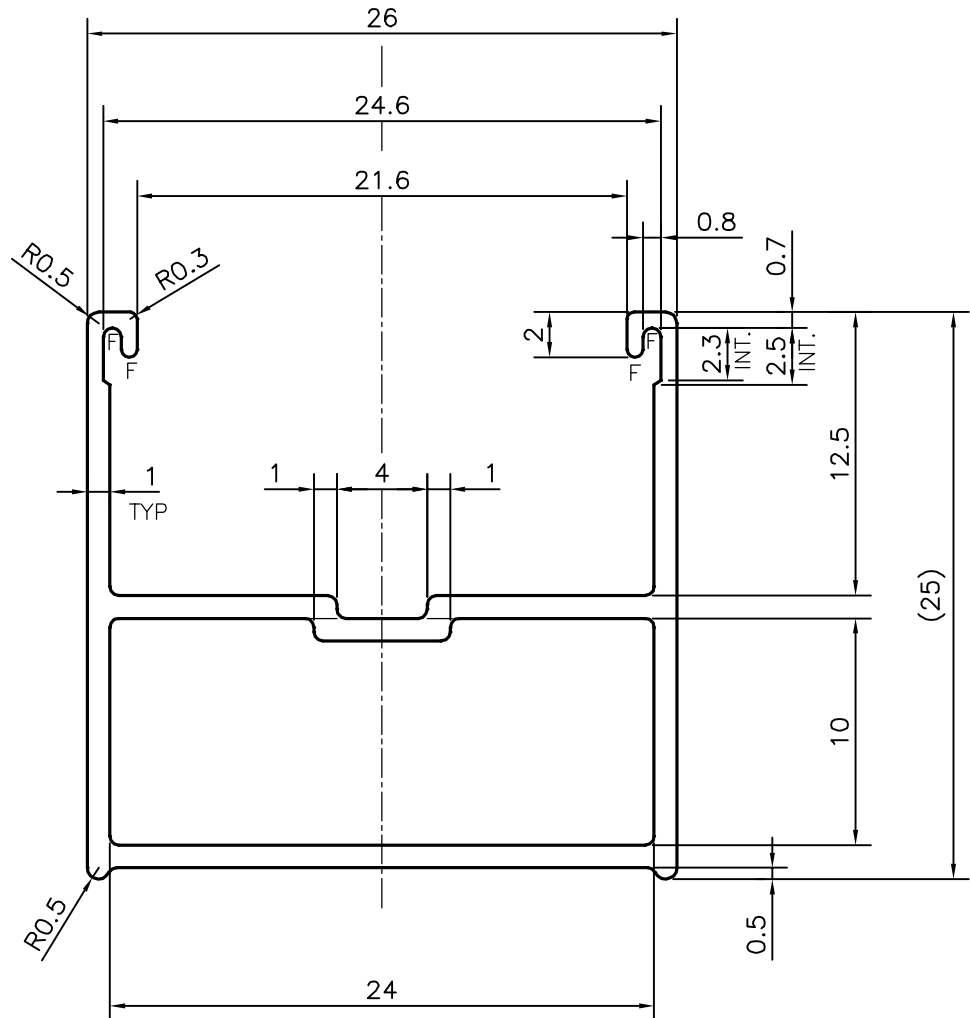

F = FULL RADIUS (4 PLACES)

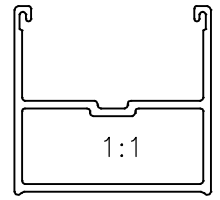

SYMBOL OF QUALITY  
AN ISO 9001 COMPANY

**JINDAL ALUMINIUM LTD.**  
BANGALORE-560073 (INDIA)

|                      | NAME        | DATE       |
|----------------------|-------------|------------|
| DRAWN                | J.P.KAUSHIK | 11-03-2015 |
| CHECKED              |             |            |
| APPROVED             | S.S.GARG    | 01-04-2015 |
| SCALE                |             | 3:1        |
| AREA mm <sup>2</sup> |             | 101.967    |
| PERIMETER mm.        |             | 136.873    |
| WEIGHT kg/m          |             | 0.275      |
| DRAWING No.          | SECTION No. |            |
| P-14482              | -           |            |
| E0287                | E0287       |            |
|                      |             |            |
|                      |             |            |

1. ALL DIMENSIONS ARE IN mm.
2. ROUND OFF ALL SHARP CORNERS WITH 0.40 mm.
3. TOLERANCES WILL BE AS PER, IS:6477-1983 UNLESS OTHERWISE SPECIFIED

|                     |                             |
|---------------------|-----------------------------|
| PARTY'S NAME        | MANTRA SOLUTIONS, NEW DELHI |
| PARTY'S DRAWING No. | AS PER DRAWING 0401         |
| ALLOY & TEMPER      | 6063 T5                     |
| DESCRIPTION         | BOTTOM RAIL                 |