

P-14484

E0289

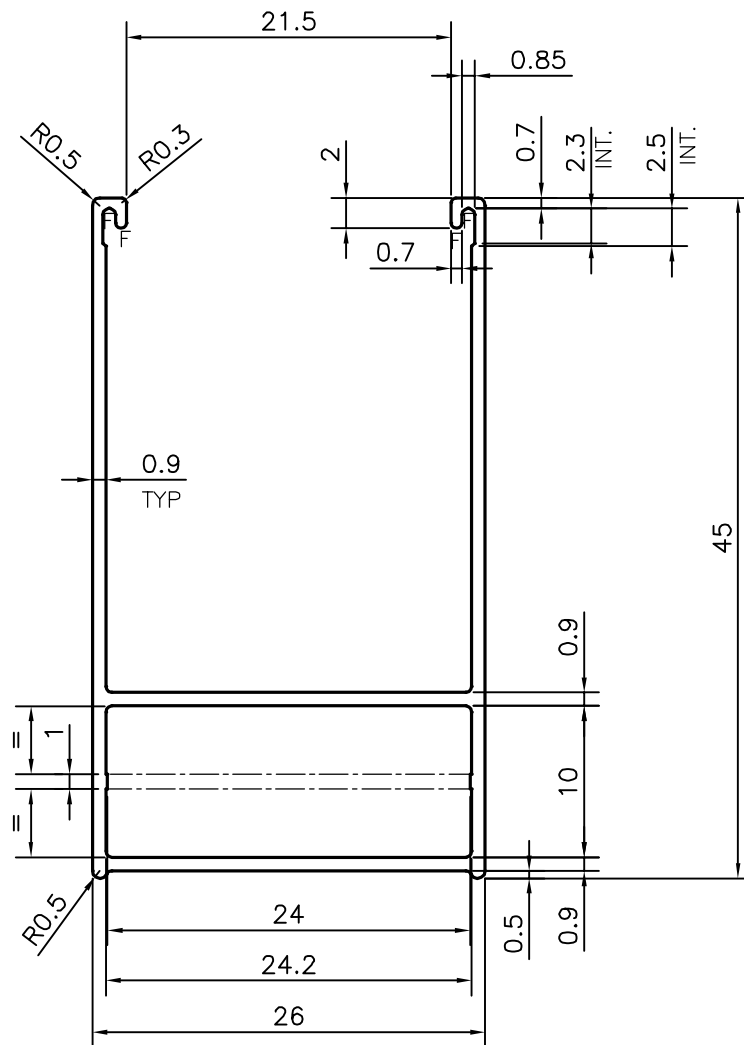

F = FULL RADIUS (4 PLACES)



SYMBOL OF QUALITY
AN ISO 9001 COMPANY

JINDAL ALUMINIUM LTD.
BANGALORE-560073 (INDIA)

	NAME	DATE
DRAWN	J.P.KAUSHIK	11-03-2015
CHECKED		
APPROVED	S.S.GARG	01-04-2015
SCALE		2:1
AREA mm ²		127.517
PERIMETER mm.		216.205
WEIGHT kg/m		0.344
DRAWING No.	SECTION No.	
P-14484	-	
E0289	E0289	

1. ALL DIMENSIONS ARE IN mm.
2. ROUND OFF ALL SHARP CORNERS WITH 0.40 mm.
3. TOLERANCES WILL BE AS PER,IS:6477-1983 UNLESS OTHERWISE SPECIFIED

PARTY'S NAME	MANTRA SOLUTIONS, NEW DELHI
PARTY'S DRAWING No.	AS PER DRAWING 0400
ALLOY & TEMPER	6063 T5
DESCRIPTION	TOP RAIL