

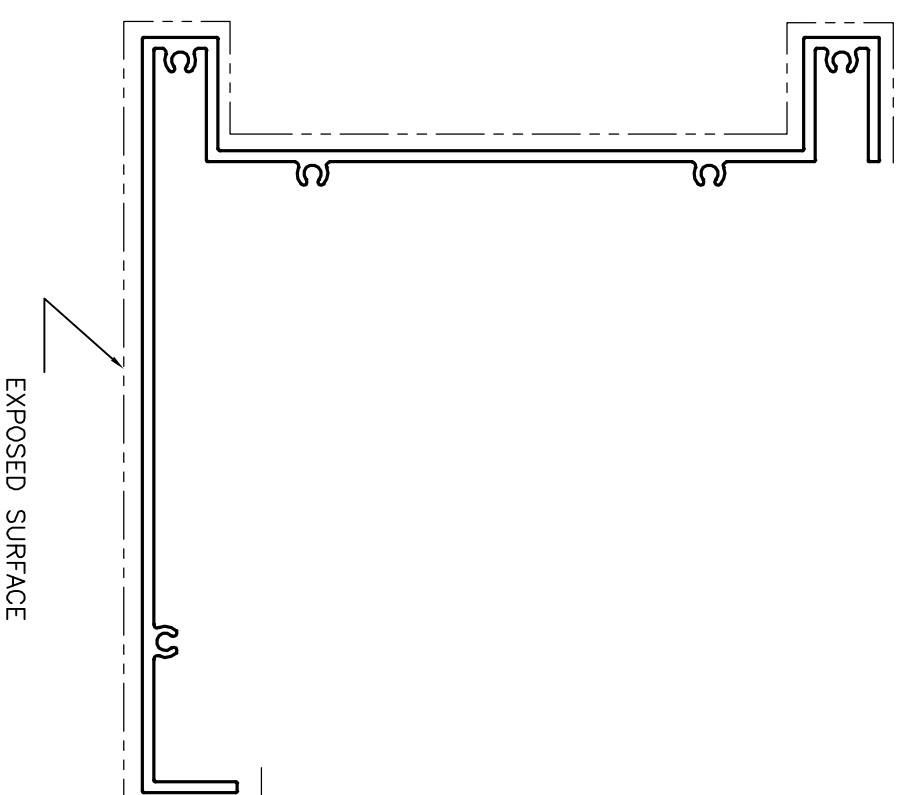

P-14614

E0298

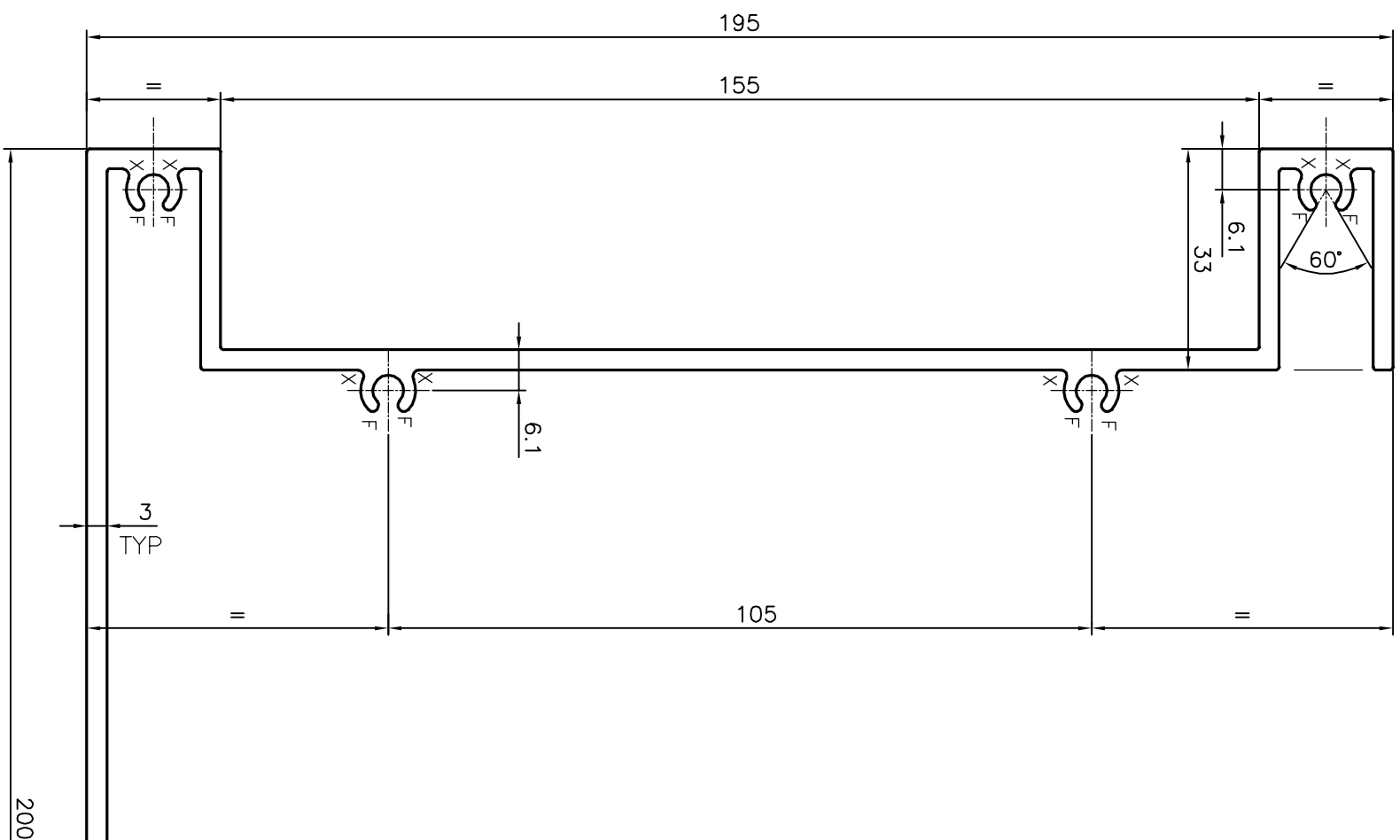

X = 1.00mm RADIUS (10 PLACES)
F = FULL RADIUS (10 PLACES)

 <p>SYMBOL OF QUALITY AN ISO 9001 COMPANY</p>		<p>JINDAL ALUMINIUM LTD. BANGALORE-560073 (INDIA)</p>	
<p>1. ALL DIMENSIONS ARE IN mm. 2. ROUND OFF ALL SHARP CORNERS WITH 0.40 mm. 3. TOLERANCES WILL BE AS PER IS:3965-1981 UNLESS OTHERWISE SPECIFIED</p>			
PARTY'S NAME	ALUFIT (INDIA) PVT. LTD., BANGALORE	DRAWN	NAME
PARTY'S DRAWING No.	AS PER AUTOCAD DRAWING	CHECKED	SUDHANVA
ALLOY & TEMPER	6063 T6	APPROVED	S.S.GARG
DESCRIPTION	COPING PROFILE	SCALE	DATE
		1:1	22-05-2015
		AREA mm ²	1647.905
		PERIMETER mm.	1114.963
		WEIGHT kg/m	4.449
		DRAWING No.	SECTION No.
		P-14614	-
		E0298	E0298