

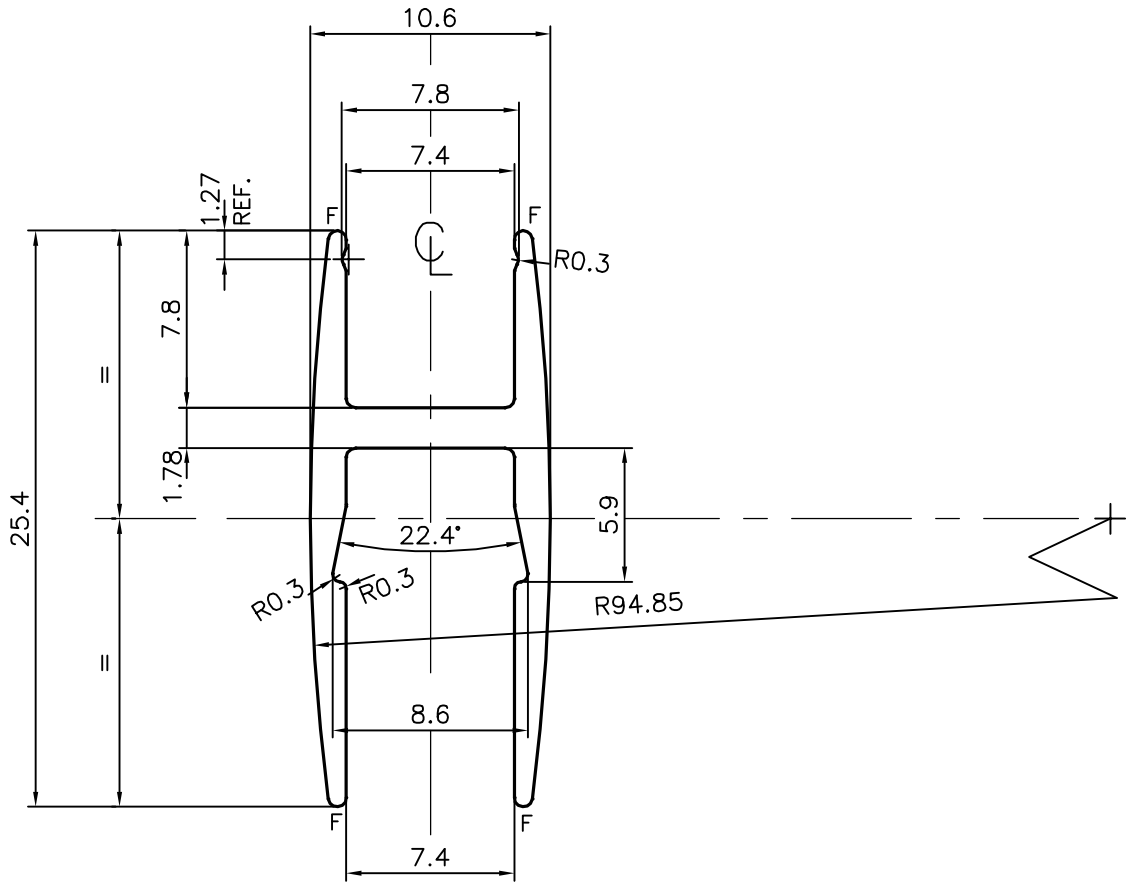

P-14779
S4521
E0337

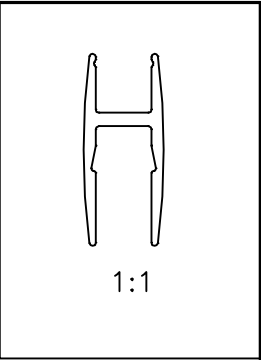

F = FULL RADIUS (4 PLACES)

 SYMBOL OF QUALITY AN ISO 9001 COMPANY	<b>JINDAL ALUMINIUM LTD.</b> BANGALORE-560073 (INDIA)	NAME	DATE
		DRAWN	J.P.KAUSHIK 17-06-2015
1. ALL DIMENSIONS ARE IN mm. 2. ROUND OFF ALL SHARP CORNERS WITH 0.40 mm. 3. TOLERANCES WILL BE AS PER IS:3965-1981 UNLESS OTHERWISE SPECIFIED		CHECKED	
		APPROVED	S.S.GARG 09-07-2015
PARTY'S NAME KEWAUNEE SCIENTIFIC CORPORATION INDIA PVT LTD., BANGALORE		SCALE	3:1
		AREA mm <sup>2</sup>	77.519
PARTY'S DRAWING No. F-6542-00		PERIMETER mm.	115.122
		WEIGHT kg/m	0.209
ALLOY & TEMPER 6063 T5		DRAWING No.	SECTION No.
		P-14779	
DESCRIPTION SLIDING GLASS SHOE-SECTION		S4521	S4521
		E0337	E0337