

P-14935-1

E0342

EXPOSED SURFACE

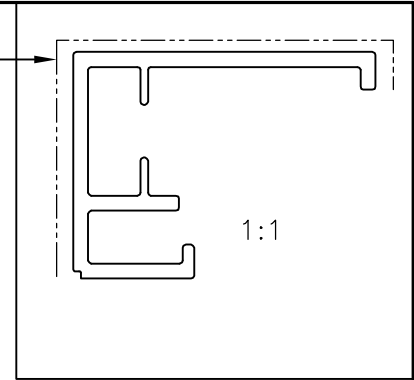
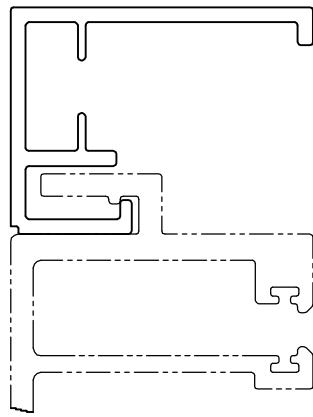

1:1

E0357

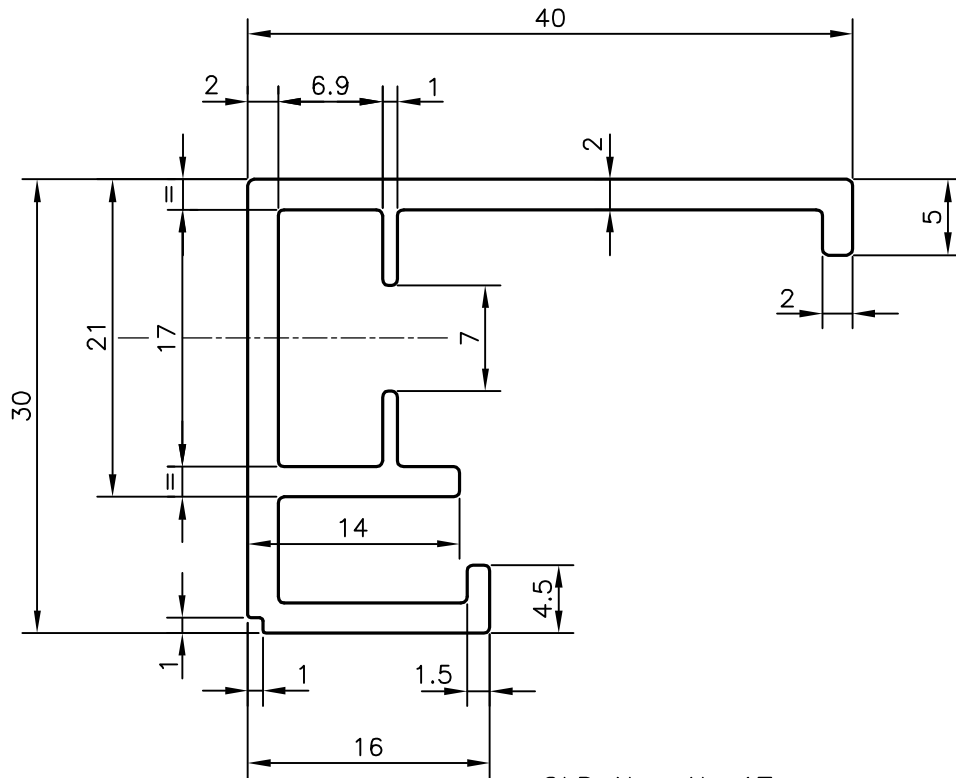

OLD No:-AL-17



SYMBOL OF QUALITY
AN ISO 9001 COMPANY

JINDAL ALUMINIUM LTD.
BANGALORE-560073 (INDIA)

| | NAME | DATE |
|----------------------|-------------|------------|
| DRAWN | J.P.KAUSHIK | 07-08-2015 |
| CHECKED | | |
| APPROVED | S.S.GARG | 12-08-2015 |
| SCALE | | 2:1 |
| AREA mm ² | | 206.638 |
| PERIMETER mm. | | 218.794 |
| WEIGHT kg/m | | 0.558 |
| DRAWING No. | SECTION No. | |
| P-14935-1 | - | |
| E0342 | E0342 | |
| | | |
| | | |

1. ALL DIMENSIONS ARE IN mm.
2. ROUND OFF ALL SHARP CORNERS WITH 0.40 mm.
3. TOLERANCES WILL BE AS PER IS:3965-1981 , UNLESS OTHERWISE SPECIFIED

| | |
|---------------------|---|
| PARTY'S NAME | ALUFIT (INDIA) PRIVATE LIMITED, BANGALORE |
| PARTY'S DRAWING No. | AL-13 |
| ALLOY & TEMPER | 6063 T6 |
| DESCRIPTION | CURTAIN WALL SECTION |