

P-14937-1

E0344

EXPOSED SURFACE

1:1

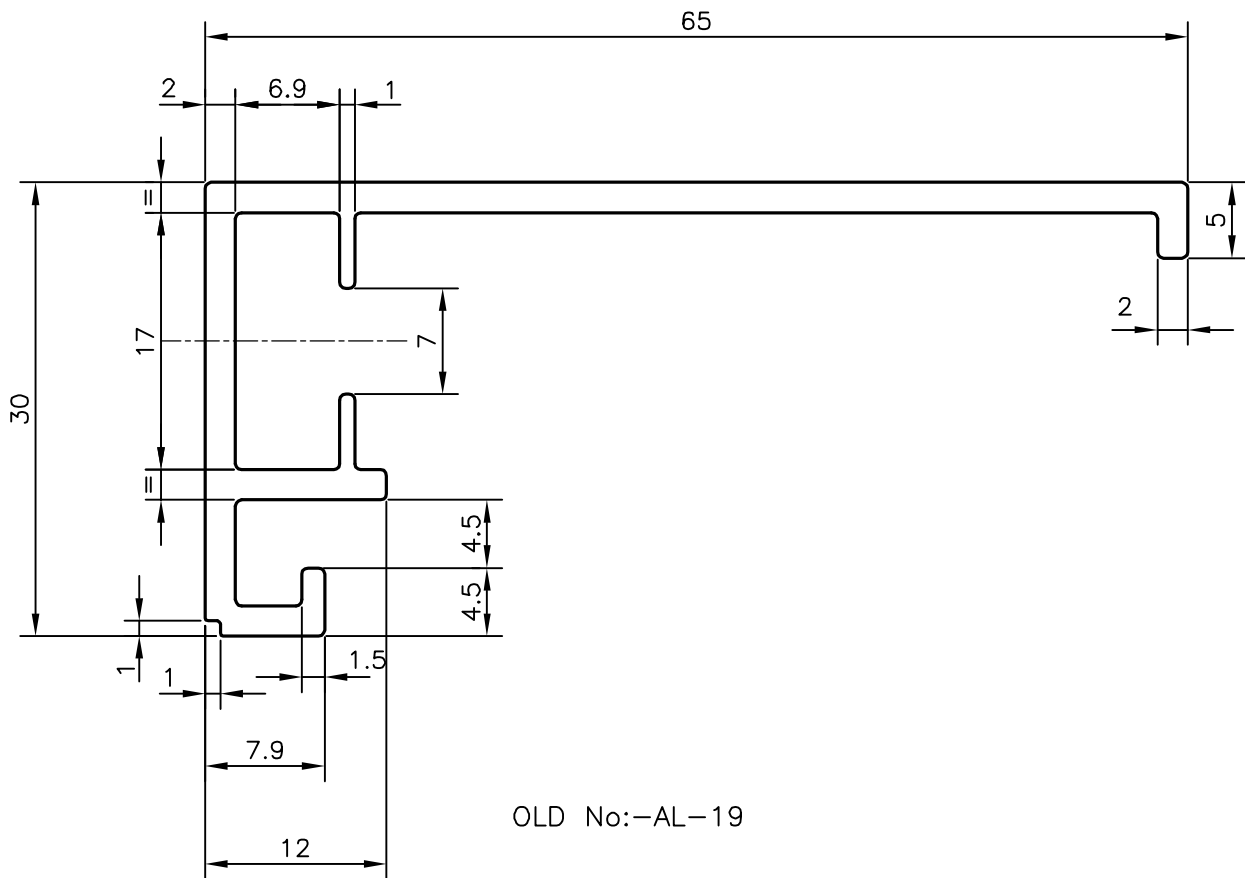
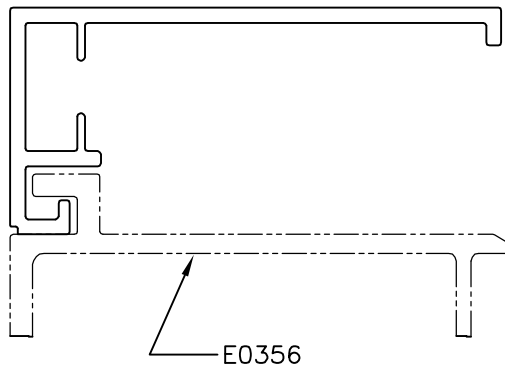

OLD No:-AL-19



SYMBOL OF QUALITY
AN ISO 9001 COMPANY

JINDAL ALUMINIUM LTD.
BANGALORE-560073 (INDIA)

	NAME	DATE
DRAWN	J.P.KAUSHIK	08-08-2015
CHECKED		
APPROVED	S.S.GARG	12-08-2015
SCALE		2:1
AREA mm ²		236.438
PERIMETER mm.		248.594
WEIGHT kg/m		0.638
DRAWING No.	SECTION No.	
P-14937-1	-	
E0344	E0344	

1. ALL DIMENSIONS ARE IN mm.
2. ROUND OFF ALL SHARP CORNERS WITH 0.40 mm.
3. TOLERANCES WILL BE AS PER IS:3965-1981 , UNLESS OTHERWISE SPECIFIED

PARTY'S NAME	ALUFIT (INDIA) PRIVATE LIMITED, BANGALORE
PARTY'S DRAWING No.	AL-15
ALLOY & TEMPER	6063 T6
DESCRIPTION	CURTAIN WALL SECTION