

P-15244

E0396

1:1

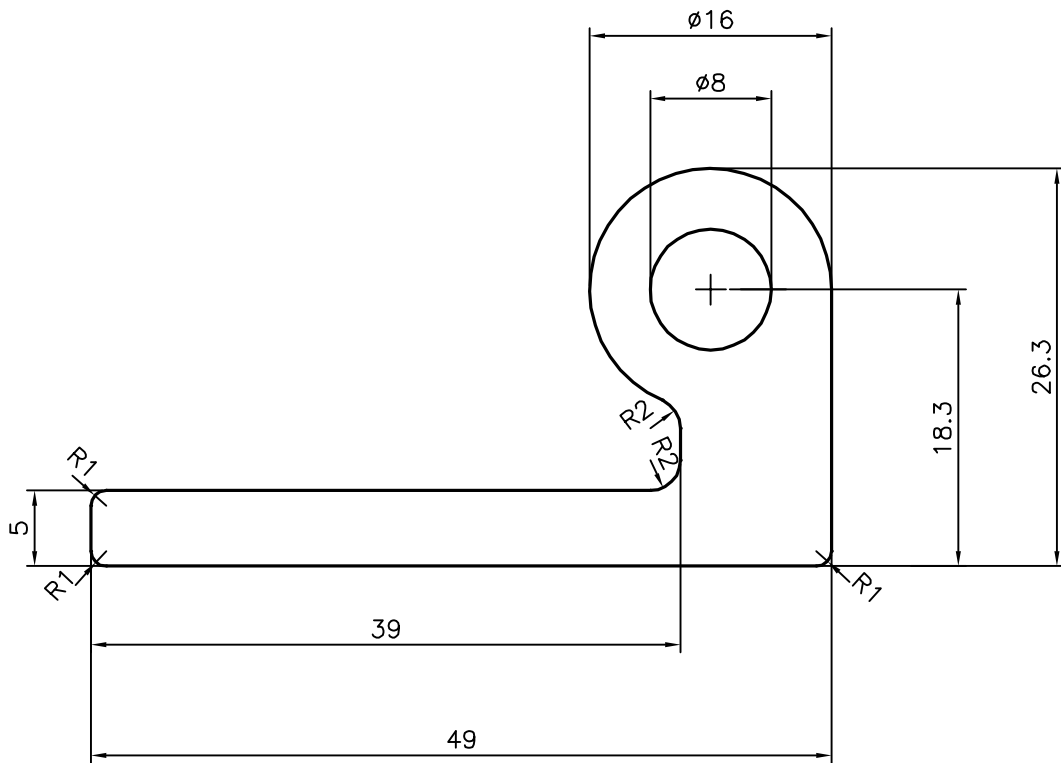
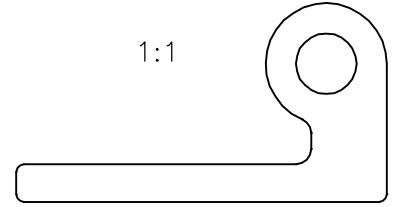

SYMBOL OF QUALITY
AN ISO 9001 COMPANY

JINDAL ALUMINIUM LTD.
BANGALORE-560073 (INDIA)

	NAME	DATE
DRAWN	J.P.KAUSHIK	16-10-2015
CHECKED		
APPROVED	S.S.GARG	24-10-2015

1. ALL DIMENSIONS ARE IN mm.
2. ROUND OFF ALL SHARP CORNERS WITH 0.40 mm.
3. TOLERANCES WILL BE AS PER BS:EN-755-9, UNLESS OTHERWISE SPECIFIED

SCALE	2:1
AREA mm ²	463.258
PERIMETER mm.	150.014
WEIGHT kg/m	1.251

PARTY'S NAME WRIGHT BUS INDIA (ENGINEERING) PVT. LTD.,
KANCHHEPURAM

DRAWING No.	SECTION No.
P-15244	-
E0396	E0396

PARTY'S DRAWING No. AUE-00468

ALLOY & TEMPER 6063 T6

DESCRIPTION HINGE SECTION