

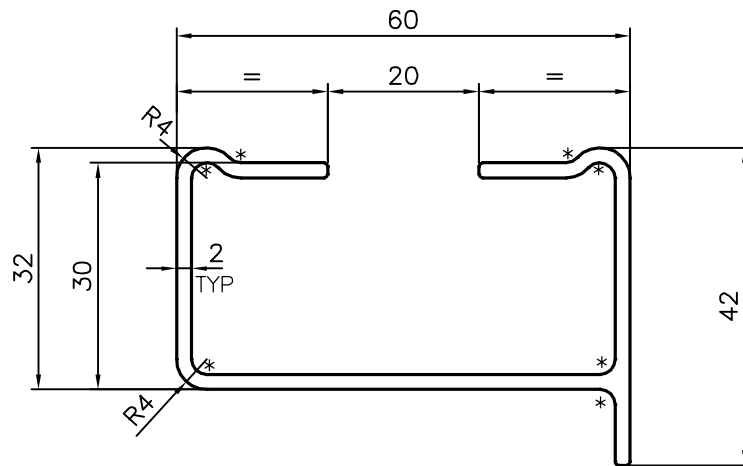

P-15246

E0397



UNSPECIFIED RADIUS 0.50 mm

\* = 2.0 RADIUS (7 PLACES)

 SYMBOL OF QUALITY AN ISO 9001 COMPANY	<b>JINDAL ALUMINIUM LTD.</b> BANGALORE-560073 (INDIA)	DRAWN	J.P.KAUSHIK	16-10-2015
		CHECKED		
1. ALL DIMENSIONS ARE IN mm. 2. ROUND OFF ALL SHARP CORNERS WITH 0.40 mm. 3. TOLERANCES WILL BE AS PER BS:EN-755-9, UNLESS OTHERWISE SPECIFIED		APPROVED	S.S.GARG	24-10-2015
		SCALE		1:1
PARTY'S NAME WRIGHT BUS INDIA (ENGINEERING) PVT. LTD., KANCHHEPURAM		AREA	mm <sup>2</sup>	327.966
		PERIMETER	mm.	327.567
PARTY'S DRAWING No. AUE-00470		WEIGHT	kg/m	0.886
		DRAWING No.		SECTION No.
ALLOY & TEMPER 6063 T6		P-15246		-
		E0397		E0397
DESCRIPTION PANEL FRAME SECTION				