

P-15245

E0398

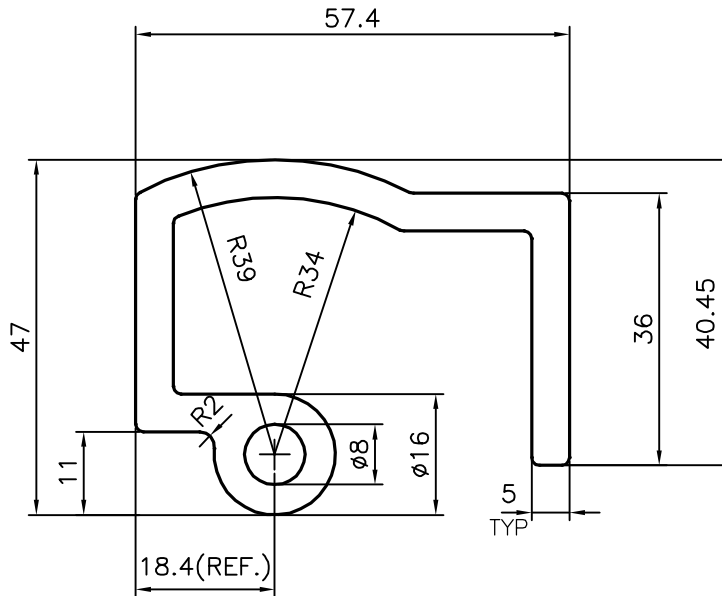

UNSPECIFIED RADIUS 1.0 mm



SYMBOL OF QUALITY  
AN ISO 9001 COMPANY

**JINDAL ALUMINIUM LTD.**  
BANGALORE-560073 (INDIA)

	NAME	DATE
DRAWN	J.P.KAUSHIK	16-10-2015
CHECKED		
APPROVED	S.S.GARG	24-10-2015

1. ALL DIMENSIONS ARE IN mm.
2. ROUND OFF ALL SHARP CORNERS WITH 0.40 mm.
3. TOLERANCES WILL BE AS PER BS:EN-755-9, UNLESS OTHERWISE SPECIFIED

SCALE	1:1
AREA mm <sup>2</sup>	777.087
PERIMETER mm.	294.883
WEIGHT kg/m	2.098

PARTY'S NAME WRIGHT BUS INDIA (ENGINEERING) PVT. LTD.,  
KANCHHEPURAM

DRAWING No.	SECTION No.
P-15245	-
E0398	E0398

PARTY'S DRAWING No. AUE-00469

ALLOY & TEMPER 6063 T6

DESCRIPTION HINGE SECTION