

P-15378-1

E0400

EXPOSED SURFACE

SCALE :- 1:1

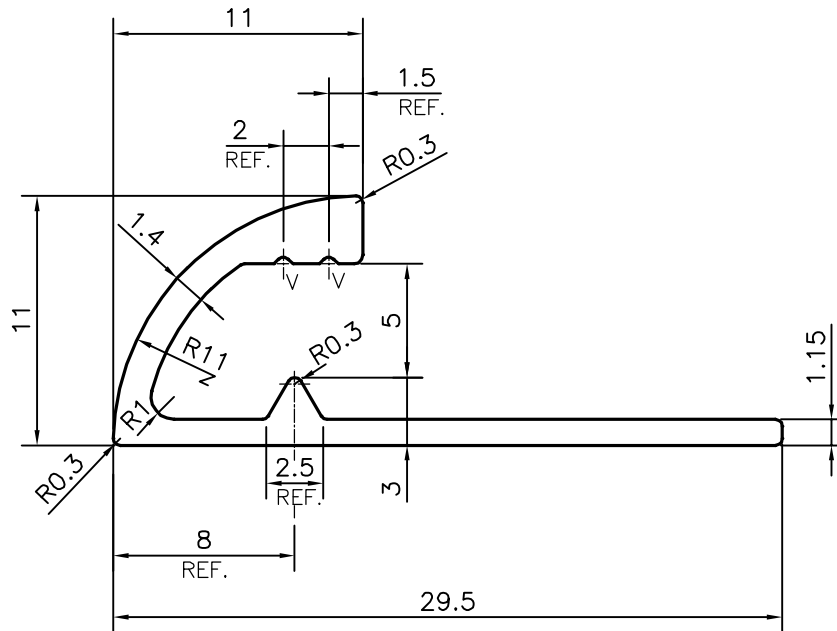

V = VEE GROOVE 0.3x90° (2 PLACES)

ROUND OFF ALL SHARP CORNERS WITH 0.30 mm.

TOLERANCES ON OVERALL WIDTHS & WIDTHS ACROSS FLATS OF BARS, & REGULAR SECTIONS

UPTO 6.40mm - ±0.20	UPTO 32.0mm - ±0.38	UPTO 120.0mm - ±0.85	1. STRAIGHTNESS=1.7mm/M 2. TWIST=1.7mm/M 3. ANGULARITY= ±2° 4. FLATNESS =0.007xWIDTH
UPTO 10.0mm - ±0.23	UPTO 50.0mm - ±0.46	UPTO 160.0mm - ±1.02	
UPTO 12.0mm - ±0.25	UPTO 60.0mm - ±0.53	UPTO 200.0mm - ±1.14	
UPTO 16.0mm - ±0.28	UPTO 80.0mm - ±0.69	UPTO 250.0mm - ±1.40	
UPTO 25.0mm - ±0.30	UPTO 100.0mm - ±0.75	UPTO 300.0mm - ±1.65	



SYMBOL OF QUALITY  
AN ISO 9001 COMPANY

**JINDAL ALUMINIUM LTD.**  
BANGALORE-560073 (INDIA)

	NAME	DATE
DRAWN	PARVESH	01-12-2015
CHECKED		
APPROVED	S.S.GARG	03-12-2015

1. ALL DIMENSIONS ARE IN mm.
2. ROUND OFF ALL SHARP CORNERS WITH 0.40 mm.
3. TOLERANCES WILL BE AS PER IS:3965-1981 , UNLESS OTHERWISE SPECIFIED

SCALE	3:1
AREA mm <sup>2</sup>	63.286
PERIMETER mm.	93.69
WEIGHT kg/m	0.171

PARTY'S NAME	SURFACES, BANGALORE	DRAWING No.	P-15378-1	SECTION No.	-
PARTY'S DRAWING No.	1533		E0400		E0400
ALLOY & TEMPER	HE9 WP				
DESCRIPTION	FURNITURE SECTION				