

P-15436

E0406

EXPOSED
SURFACE

SCALE:- 1:1

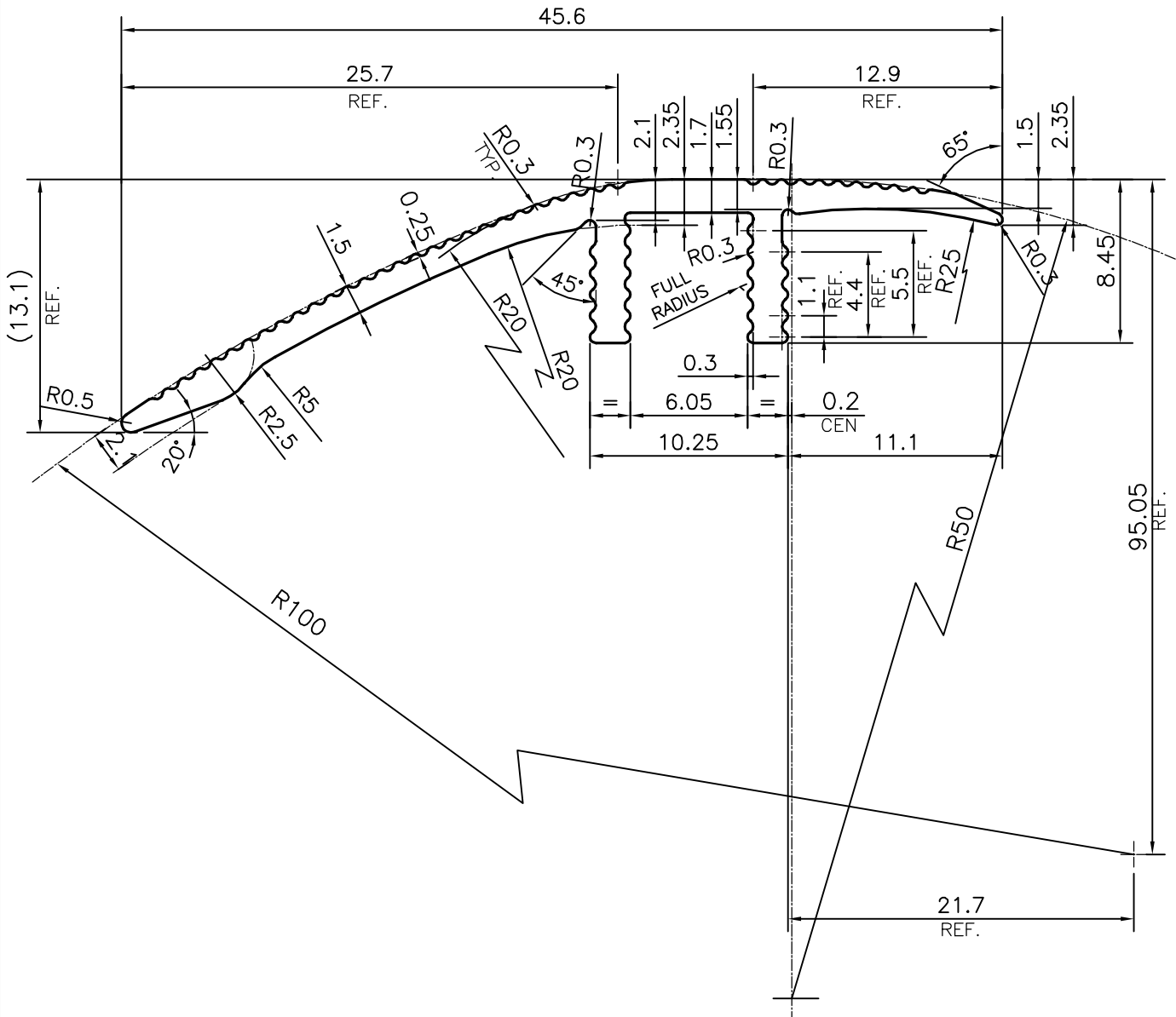

SYMBOL OF QUALITY
AN ISO 9001 COMPANY

JINDAL ALUMINIUM LTD.
BANGALORE-560073 (INDIA)

	NAME	DATE
DRAWN	PARVESH	15-12-2015
CHECKED		
APPROVED	S.S.GARG	16-12-2015

1. ALL DIMENSIONS ARE IN mm.
2. ROUND OFF ALL SHARP CORNERS WITH 0.40 mm.
3. TOLERANCES WILL BE AS PER IS:3965-1981 , UNLESS OTHERWISE SPECIFIED

SCALE	3:1
AREA mm ²	92.192
PERIMETER mm.	135.243
WEIGHT kg/m	0.249

PARTY'S NAME	SURFACES, BANGALORE	DRAWING No.	P-15436	SECTION No.	-
PARTY'S DRAWING No.	AS PER CUSTOMER REQUIREMENT		E0406		E0406
ALLOY & TEMPER	HE9 WP				
DESCRIPTION	FURNITURE SECTION				