

P-15368

E0409

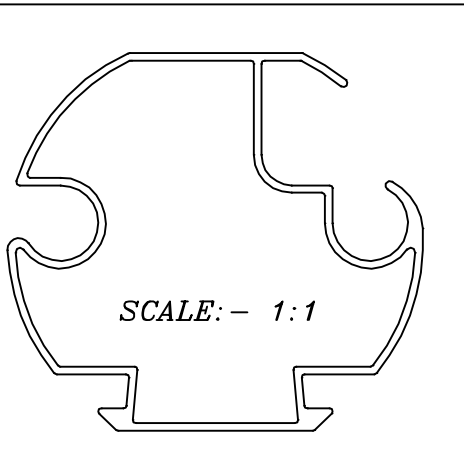

F = FUL RADIUS (2 PLACES)

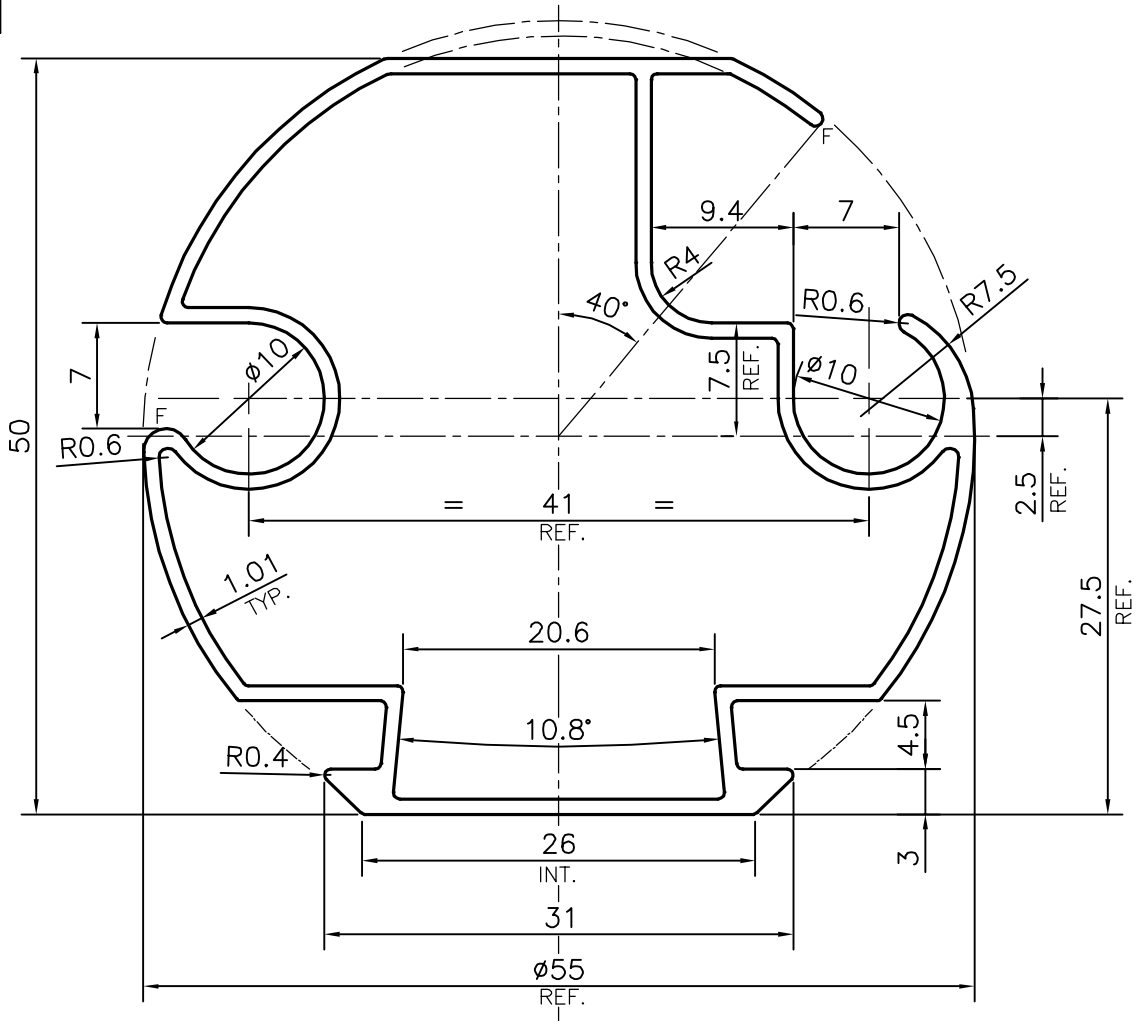

SYMBOL OF QUALITY
AN ISO 9001 COMPANY

JINDAL ALUMINIUM LTD.
BANGALORE-560073 (INDIA)

	NAME	DATE
DRAWN	PARVESH	24-12-2015
CHECKED		
APPROVED	S.S.GARG	25-12-2015
SCALE		2:1
AREA mm ²		254.315
PERIMETER mm.		264.312
WEIGHT kg/m		0.687
DRAWING No.	SECTION No.	
P-15368	-	
E0409	E0409	

1. ALL DIMENSIONS ARE IN mm.
2. ROUND OFF ALL SHARP CORNERS WITH 0.40 mm.
3. TOLERANCES WILL BE AS PER IS:6477-1983 , UNLESS OTHERWISE SPECIFIED

PARTY'S NAME	ADARSH ALUMINIUM WORKS, DELHI
PARTY'S DRAWING No.	NEAREST OF SECTION No.-22077, & REQUIREMENT
ALLOY & TEMPER	HE9 WP
DESCRIPTION	VENETIAN BLINDS SECTION