

P-15334-1

E0411

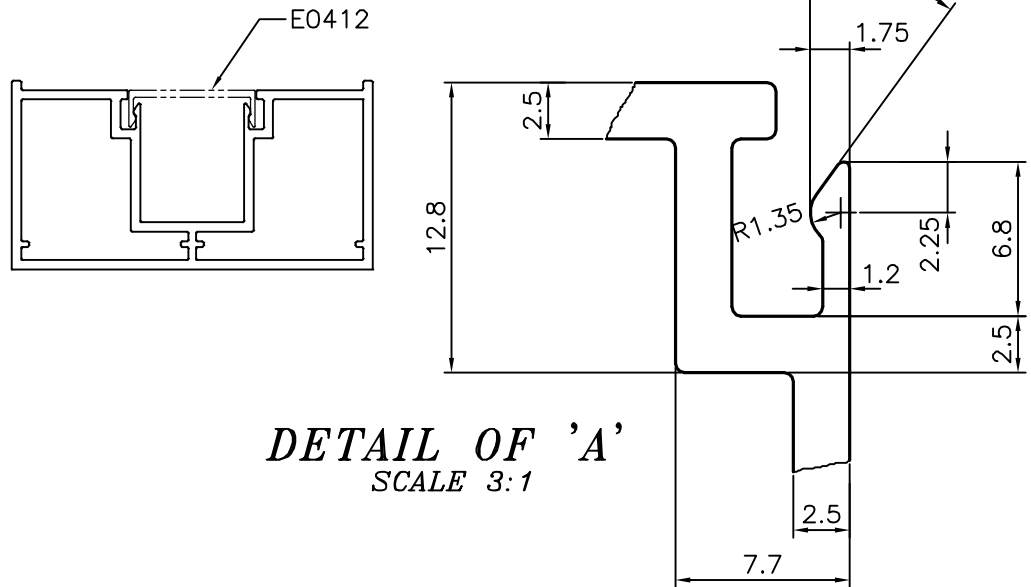

DETAIL OF 'A'
SCALE 3:1

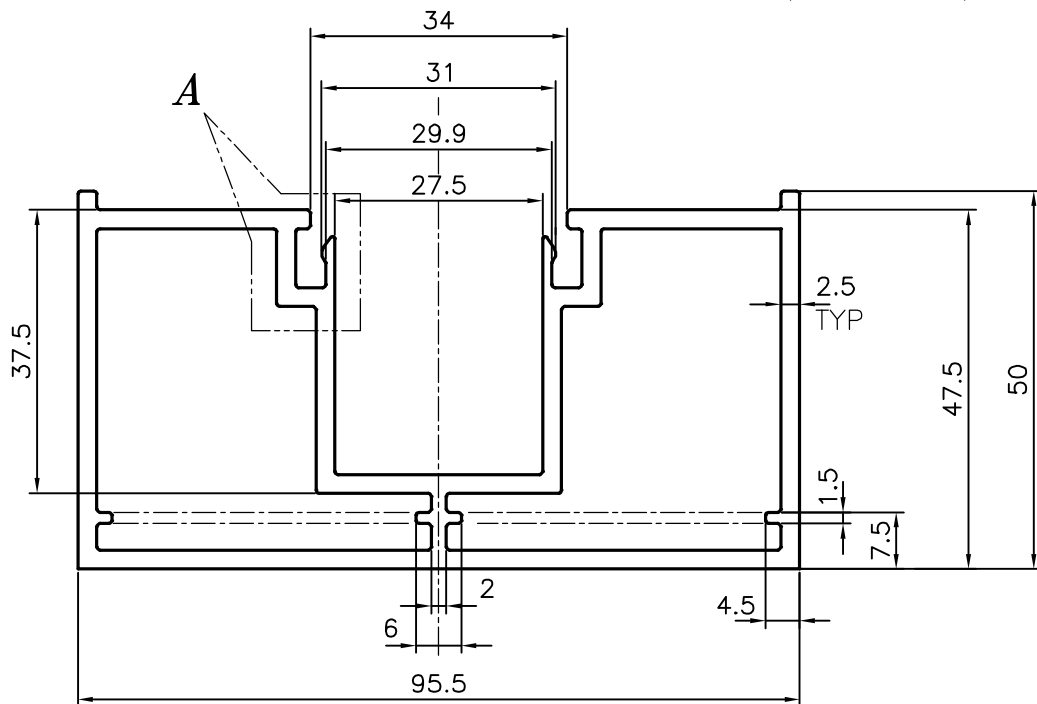

SYMBOL OF QUALITY
AN ISO 9001 COMPANY

JINDAL ALUMINIUM LTD.
BANGALORE-560073 (INDIA)

	NAME	DATE
DRAWN	J.P.KAUSHIK	26-11-2015
CHECKED		
APPROVED	S.S.GARG	25-12-2015
SCALE		1:1
AREA mm ²		931.735
PERIMETER mm.		397.19
WEIGHT kg/m		2.516
DRAWING No.	SECTION No.	
P-15334-1	-	
E0411	E0411	

1. ALL DIMENSIONS ARE IN mm.
2. ROUND OFF ALL SHARP CORNERS WITH 0.40 mm.
3. TOLERANCES WILL BE AS PER IS:6477-1983 , UNLESS OTHERWISE SPECIFIED

PARTY'S NAME	ALUFIT (INDIA) PRIVATE LIMITED, BANGALORE
PARTY'S DRAWING No.	GDR-R-04
ALLOY & TEMPER	6063 T6
DESCRIPTION	TRANSOM-2 CURTAIN WALL SECTION