

P-15390

E0420

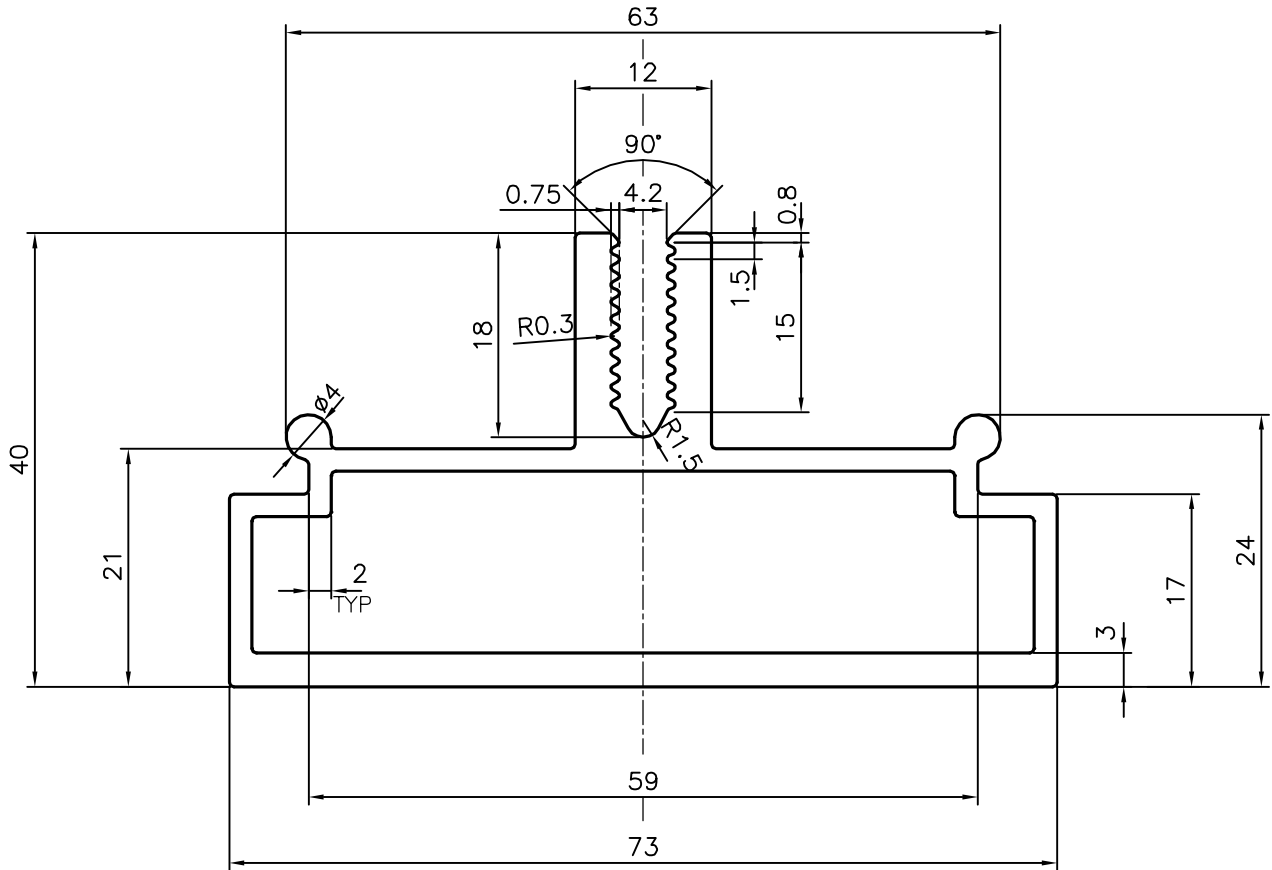
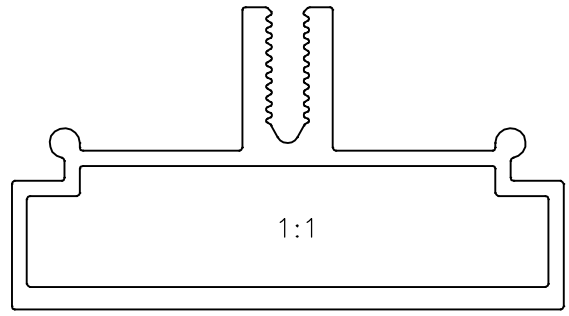

SYMBOL OF QUALITY
AN ISO 9001 COMPANY

JINDAL ALUMINIUM LTD.
BANGALORE-560073 (INDIA)

	NAME	DATE
DRAWN	J.P.KAUSHIK	03-12-2015
CHECKED		
APPROVED	S.S.GARG	25-12-2015
SCALE		1.5:1
AREA mm ²		595.709
PERIMETER mm.		286.855
WEIGHT kg/m		1.608
DRAWING No.	SECTION No.	
P-15390	-	
E0420	E0420	

1. ALL DIMENSIONS ARE IN mm.
2. ROUND OFF ALL SHARP CORNERS WITH 0.40 mm.
3. TOLERANCES WILL BE AS PER IS:6477-1983 , UNLESS OTHERWISE SPECIFIED

PARTY'S NAME	ALUFIT (INDIA) PRIVATE LIMITED, BANGALORE
PARTY'S DRAWING No.	SKL-2
ALLOY & TEMPER	6063 T6
DESCRIPTION	MULLION CURTAIN WALL SECTION