

P-15521

E0432

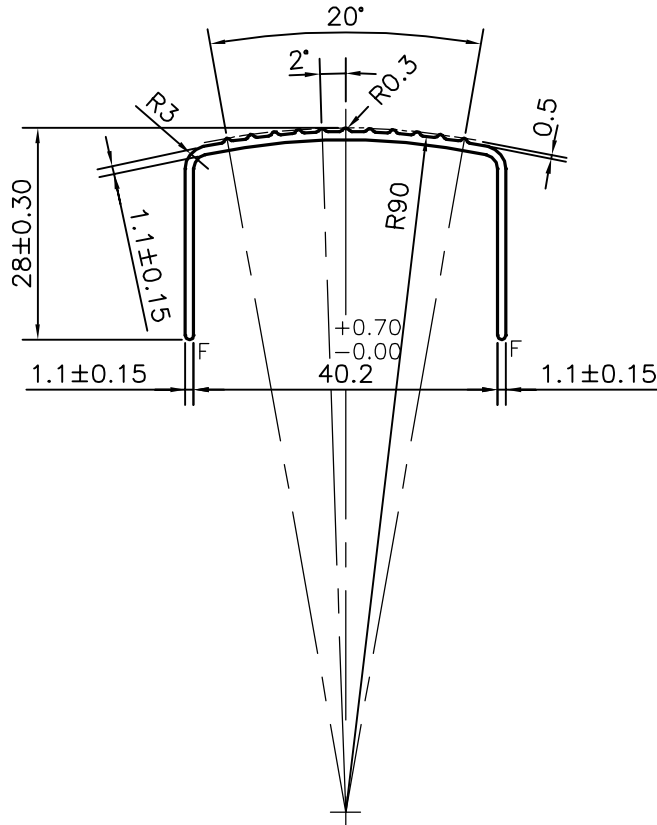

F = FULL RADIUS (2 PLACES)

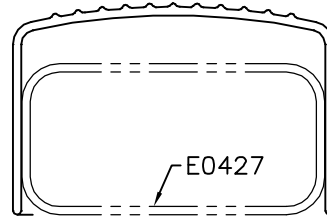

SYMBOL OF QUALITY
AN ISO 9001 COMPANY

JINDAL ALUMINIUM LTD.
BANGALORE-560073 (INDIA)

	NAME	DATE
DRAWN	J.P.KAUSHIK	20-01-2016
CHECKED		
APPROVED	B. NATARAJ	12-02-2016
SCALE		1:1
AREA mm ²		102.367
PERIMETER mm.		184.217
WEIGHT kg/m		0.276
DRAWING No.	SECTION No.	
P-15521	-	
E0432	E0432	

1. ALL DIMENSIONS ARE IN mm.
2. ROUND OFF ALL SHARP CORNERS WITH 0.40 mm.
3. TOLERANCES WILL BE AS PER, IS:3965-1981 UNLESS OTHERWISE SPECIFIED

PARTY'S NAME	AGUERRI INDUSTRIES PVT. LTD., CHENNAI
PARTY'S DRAWING No.	04655
ALLOY & TEMPER	6063 T5
DESCRIPTION	REFUERZO/REINFORCEMENTE PROFILE