

P-8028
X877
34501
X877
E0439

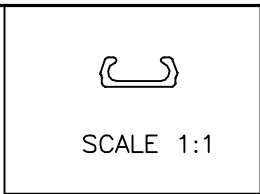

MATCHING SECTION

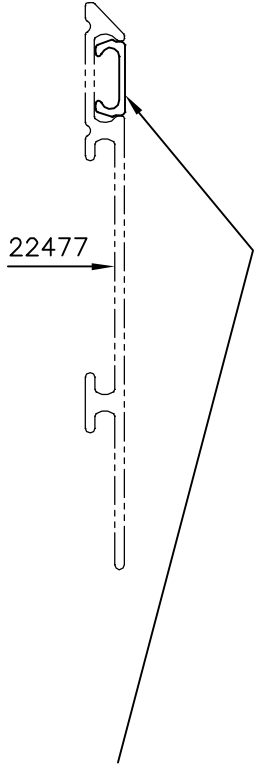
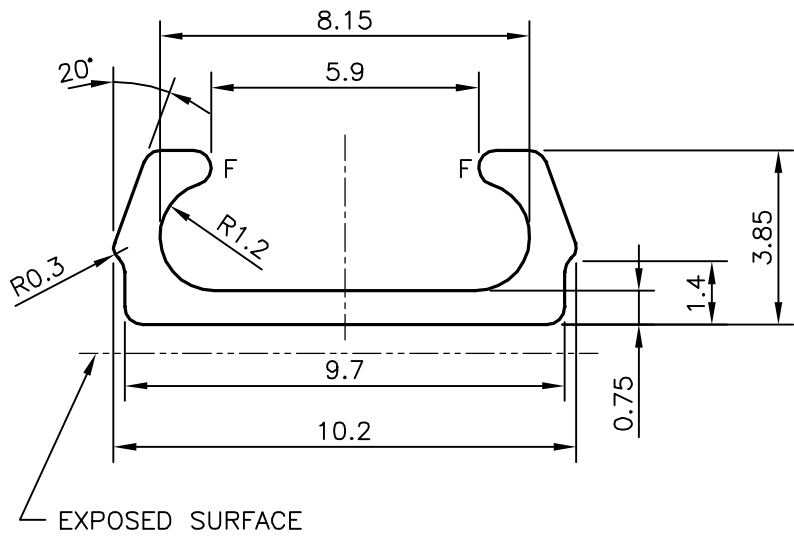

F = FULL RADIUS (2 PLACES)

<p>SYMBOL OF QUALITY AN ISO 9001 COMPANY</p>	<p><b>JINDAL ALUMINIUM LTD.</b> BANGALORE-560073 (INDIA)</p>	NAME	DATE
		DRAWN	PRASANNA.H 19-03-2008
<p>1. ALL DIMENSIONS ARE IN mm. 2. ROUND OFF ALL SHARP CORNERS WITH 0.40 mm. 3. TOLERANCES WILL BE AS PER IS:3965-1981 UNLESS OTHERWISE SPECIFIED</p>		CHECKED	
		APPROVED	
<p>PARTY'S NAME SURFACES, BANGALORE</p>		SCALE	6:1
		AREA mm <sup>2</sup>	14.294
<p>PARTY'S DRAWING No. AS PER SAMPLE</p>		PERIMETER mm.	34.107
		WEIGHT kg/m	0.039
<p>ALLOY &amp; TEMPER HE9 WP</p>		DRAWING No.	SECTION No.
		P-8028	-
<p>DESCRIPTION FURNITURE SECTION</p>		X877	X877
		34501	34501
		X877	X877
		E0439	E0439