

P-8453

X981

E0443

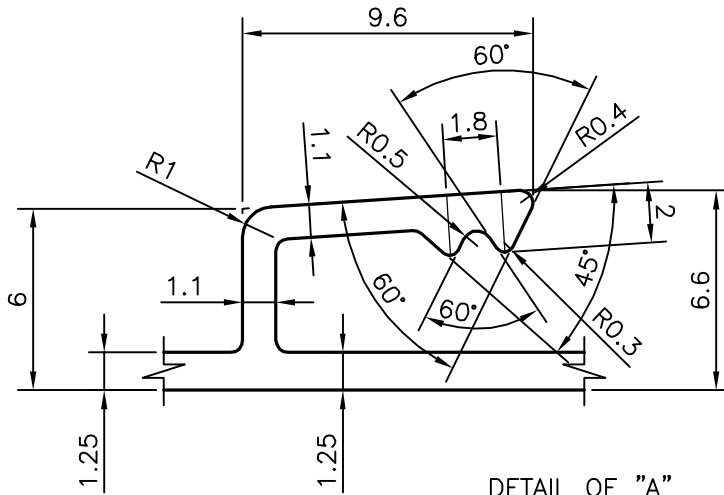
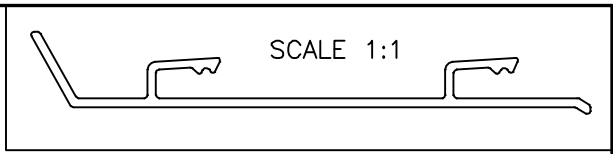

DETAIL OF "A"
SCALE 4:1

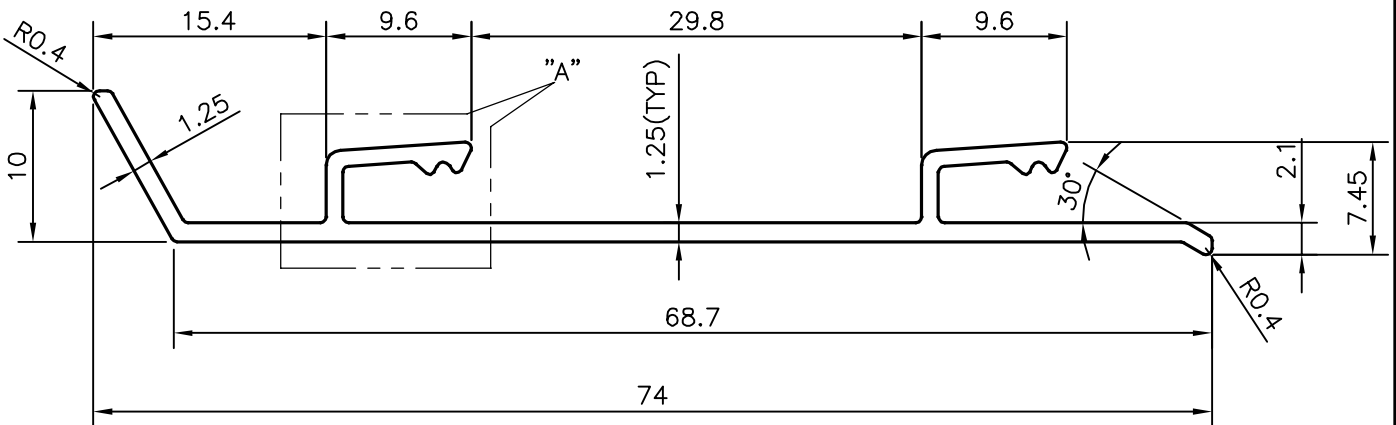

JINDAL ALUMINIUM LTD.
BANGALORE-560073 (INDIA)

	NAME	DATE
DRAWN	PRASANNA.H	16-07-2008
CHECKED		
APPROVED		

1. ALL DIMENSIONS ARE IN mm.
2. ROUND OFF ALL SHARP CORNERS WITH 0.40 mm.
3. TOLERANCES WILL BE AS PER IS:3965-1981 UNLESS OTHERWISE SPECIFIED

SCALE	2:1
AREA mm ²	131.337
PERIMETER mm.	214.057
WEIGHT kg/m	0.355

PARTY'S NAME	SURFACES, BANGALORE
PARTY'S DRAWING No.	AS PER SAMPLE & CUSTOMER REQUIREMENT
ALLOY & TEMPER	HE9 WP
DESCRIPTION	FURNITURE SECTION

DRAWING No.	SECTION No.
P-8453	-
X981	X981
E0443	E0443