

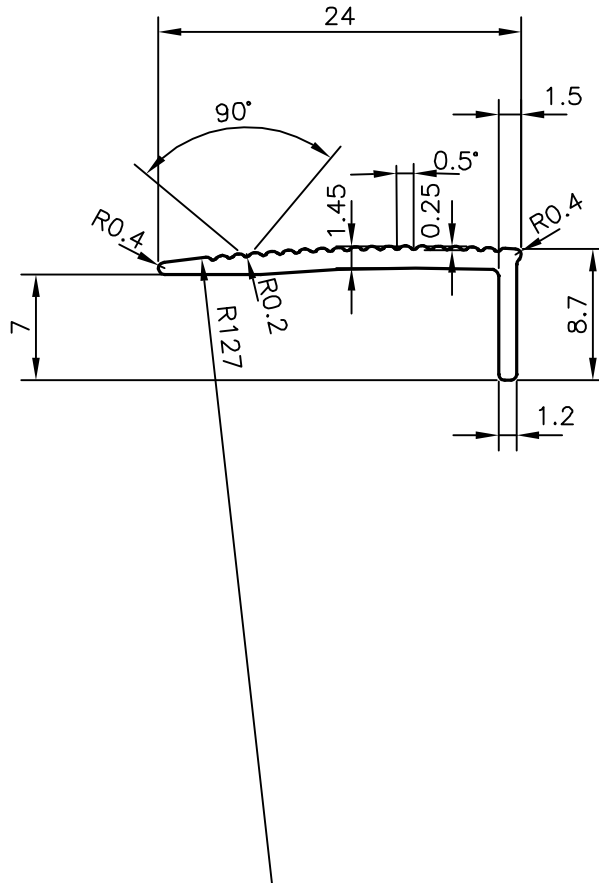

P-9783
X1259
E0454

EXPOSED SURFACE

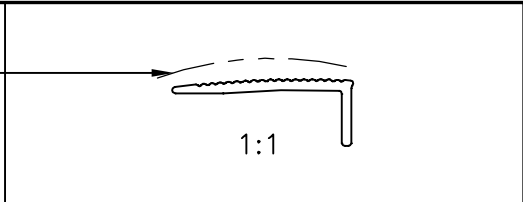

 SYMBOL OF QUALITY AN ISO 9001 COMPANY	JINDAL ALUMINIUM LTD. BANGALORE-560073 (INDIA)	NAME		DATE	
		DRAWN	J.P.KAUSHIK	05-02-2010	
1. ALL DIMENSIONS ARE IN mm. 2. ROUND OFF ALL SHARP CORNERS WITH 0.40 mm. 3. TOLERANCES WILL BE AS PER IS:3965-1981, UNLESS OTHERWISE SPECIFIED		CHECKED			
		APPROVED		S.S.GARG	25-02-2010
PARTY'S NAME		SURFACES, BANGALORE		SCALE	2:1
		PARTY'S DRAWING No.		AS PER SAMPLE	AREA mm ²
ALLOY & TEMPER		HE9 WP		PERIMETER mm.	66.424
		DESCRIPTION		MISC. SECTION	WEIGHT kg/m
		DRAWING No.		SECTION No.	
		P-9783		-	
		X1259		X1259	
		E0454		E0454	