

P-13384

X1725

E0455

1:1

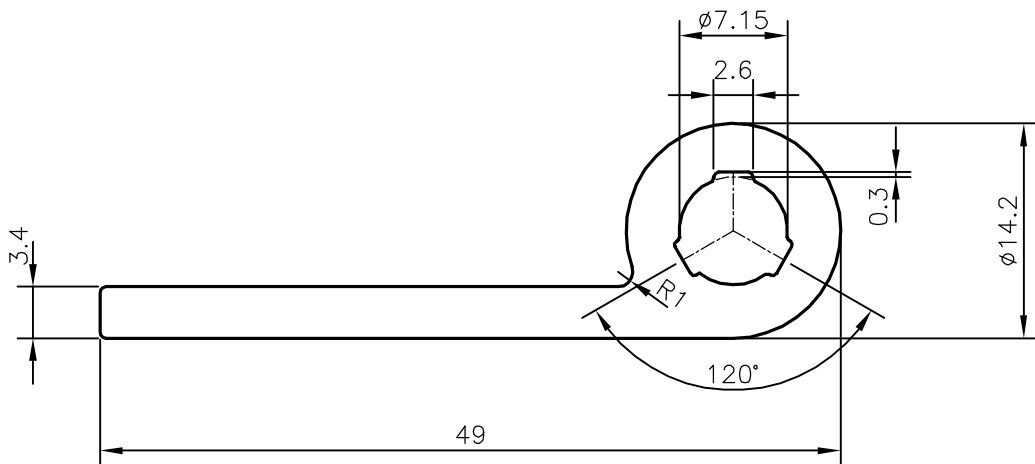
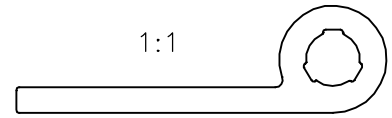

SYMBOL OF QUALITY  
AN ISO 9001 COMPANY

**JINDAL ALUMINIUM LTD.**  
BANGALORE-560073 (INDIA)

	NAME	DATE
DRAWN	J.P.KAUSHIK	28-01-2014
CHECKED		
APPROVED	S.S.GARG	31-01-2014
SCALE		2:1
AREA mm <sup>2</sup>		243.705
PERIMETER mm.		117.001
WEIGHT kg/m		0.658
DRAWING No.	SECTION No.	
P-13384	-	
X1725	X1725	
E0455	E0455	

1. ALL DIMENSIONS ARE IN mm.
2. ROUND OFF ALL SHARP CORNERS WITH 0.40 mm.
3. TOLERANCES WILL BE AS PER IS:6477-1983 UNLESS OTHERWISE SPECIFIED

PARTY'S NAME SURFACES., BANGALORE

PARTY'S DRAWING No. AS PER SAMPLE

ALLOY & TEMPER HE9 WP

DESCRIPTION HINGE SECTION