

P-15787

E0464

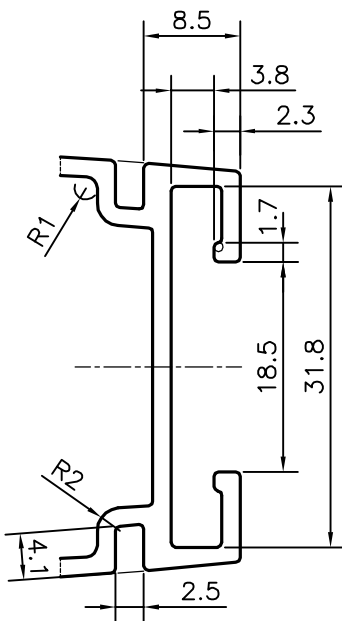

DETAIL OF "A"
SCALE 1.5:1

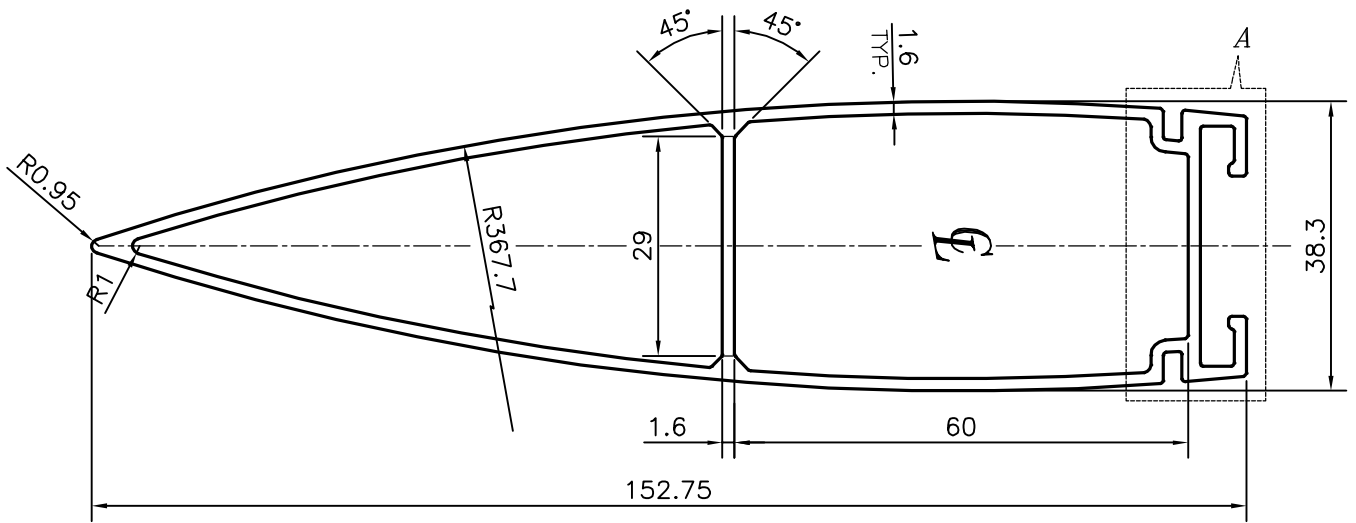

SYMBOL OF QUALITY
AN ISO 9001 COMPANY

JINDAL ALUMINIUM LTD.
BANGALORE-560073 (INDIA)

	NAME	DATE
DRAWN	PARVESH	15-04-2016
CHECKED		
APPROVED	S.S. GARG	20-04-2016
SCALE		1:1
AREA mm ²		646.614
PERIMETER mm.		399.32
WEIGHT kg/m		1.746
DRAWING No.	SECTION No.	
P-15787	-	
E0464	E0464	

1. ALL DIMENSIONS ARE IN mm.
2. ROUND OFF ALL SHARP CORNERS WITH 0.40 mm.
3. TOLERANCES WILL BE AS PER IS:6477-1983 , UNLESS OTHERWISE SPECIFIED

PARTY'S NAME	SHREEJI INTERIORS, BANGALORE
PARTY'S DRAWING No.	AS PER PROPOSAL DRAWING & REQUIREMENT
ALLOY & TEMPER	HE9 WP
DESCRIPTION	LOUVER SECTION