

P-15789

E0466

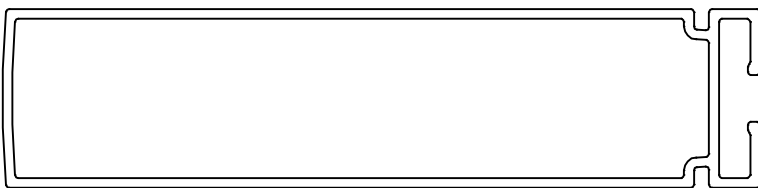

SCALE :- 1:1

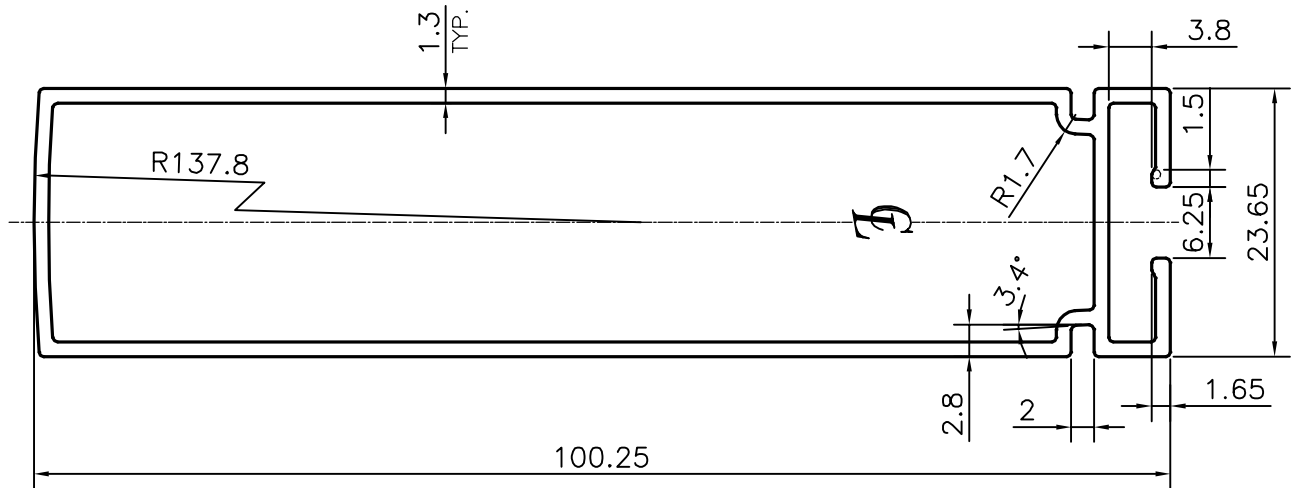

SYMBOL OF QUALITY
AN ISO 9001 COMPANY

JINDAL ALUMINIUM LTD.
BANGALORE-560073 (INDIA)

	NAME	DATE
DRAWN	PARVESH	15-04-2016
CHECKED		
APPROVED	S.S. GARG	20-04-2016
SCALE		1.5:1
AREA mm ²		340.4
PERIMETER mm.		295.937
WEIGHT kg/m		0.919
DRAWING No.	SECTION No.	
P-15789	-	
E0466	E0466	

1. ALL DIMENSIONS ARE IN mm.
2. ROUND OFF ALL SHARP CORNERS WITH 0.40 mm.
3. TOLERANCES WILL BE AS PER IS:6477-1983 , UNLESS OTHERWISE SPECIFIED

PARTY'S NAME	SHREEJI INTERIORS, BANGALORE
PARTY'S DRAWING No.	AS PER PROPOSAL DRAWING & REQUIREMENT
ALLOY & TEMPER	HE9 WP
DESCRIPTION	LOUVER SECTION