

P-15806

EXPOSED SURFACE

E0468



1:1

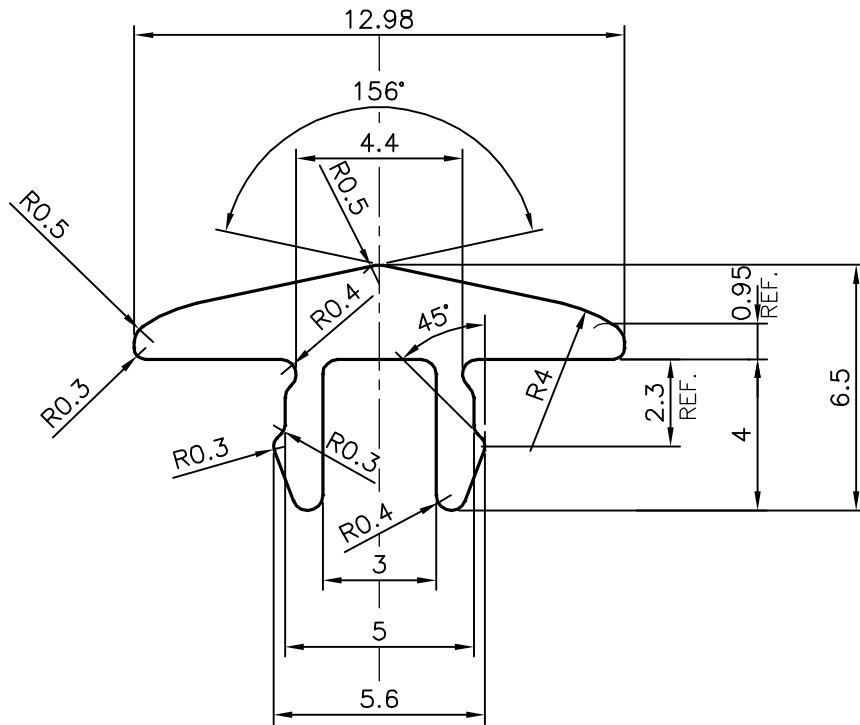

SYMBOL OF QUALITY
AN ISO 9001 COMPANY

JINDAL ALUMINIUM LTD.
BANGALORE-560073 (INDIA)

	NAME	DATE
DRAWN	J.P.KAUSHIK	26-04-2016
CHECKED		
APPROVED	S.S. GARG	03-05-2016

1. ALL DIMENSIONS ARE IN mm.
2. ROUND OFF ALL SHARP CORNERS WITH 0.40 mm.
3. TOLERANCES WILL BE AS PER IS:3965-1981 UNLESS OTHERWISE SPECIFIED

SCALE	5:1
AREA mm ²	30.902
PERIMETER mm.	43.019
WEIGHT kg/m	0.083

PARTY'S NAME	TORFENSTER SYSTEMS (INDIA) PVT. LTD., BANGALORE
PARTY'S DRAWING No.	AS PER DRAWING
ALLOY & TEMPER	6063 T6
DESCRIPTION	RAIL FOR SLIDING SHUTTER SECTION

DRAWING No.	SECTION No.
P-15806	-
E0468	E0468