

P-15465

E0469

EXPOSED SURFACE

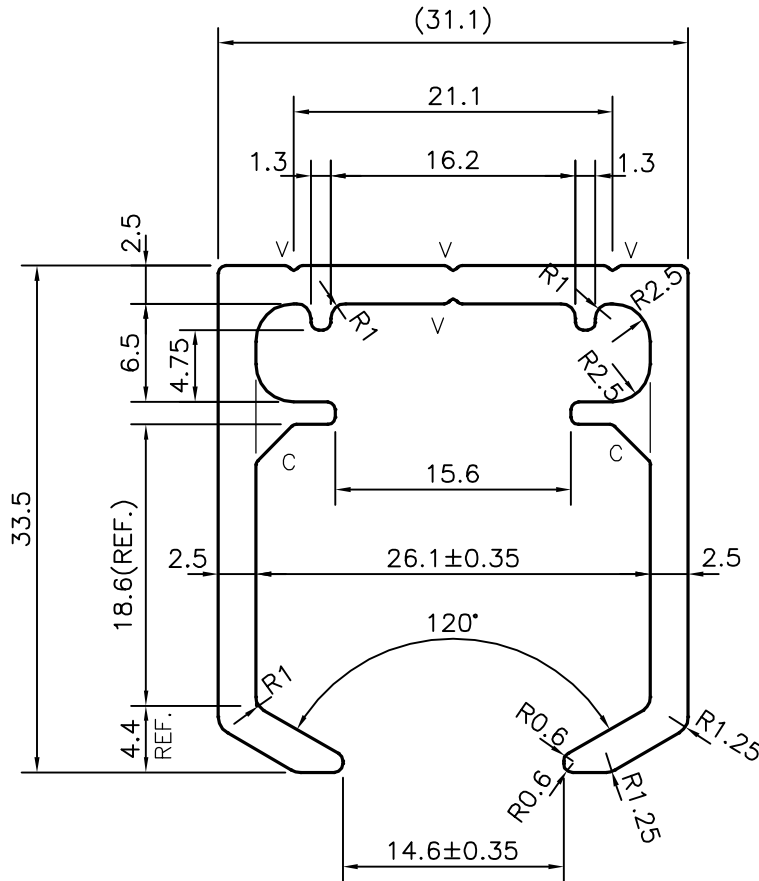
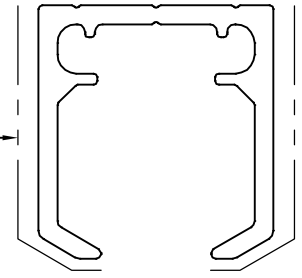

C = CHAMFER 2.5x45° (2 PLACES)
 V = V GROOVE 0.3x90° (4 PLACES)



SYMBOL OF QUALITY
 AN ISO 9002 COMPANY

JINDAL ALUMINIUM LTD.
 BANGALORE-560073 (INDIA)

	NAME	DATE
DRAWN	J.P.KAUSHIK	31-12-2015
CHECKED		
APPROVED	B. NATARAJ	07-05-2016
SCALE		2:1
AREA mm ²		280.428
PERIMETER mm.		221.453
WEIGHT kg/m		0.757
DRAWING No.	SECTION No.	
P-15465	-	
E0469	E0469	

1. ALL DIMENSIONS ARE IN mm.
2. ROUND OFF ALL SHARP CORNERS WITH 0.40 mm.
3. TOLERANCES WILL BE AS PER BS:EN-12020-2 UNLESS OTHERWISE SPECIFIED

PARTY'S NAME	HAFELE INDIA PVT. LTD., MUMBAI
PARTY'S DRAWING No.	ETPA172A00000
ALLOY & TEMPER	6060 T5
DESCRIPTION	MISC. SECTION