

P-15494

E0484

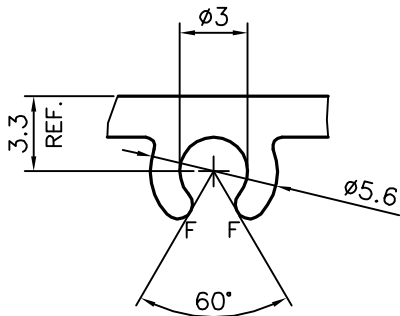
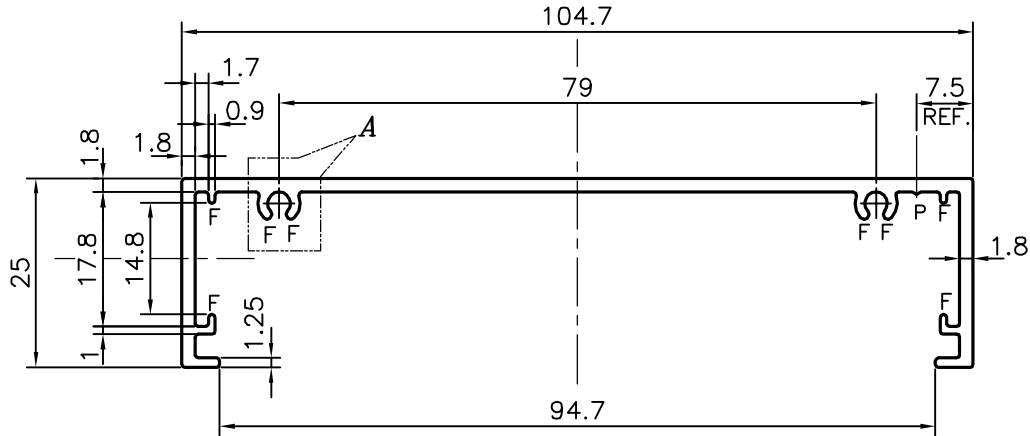
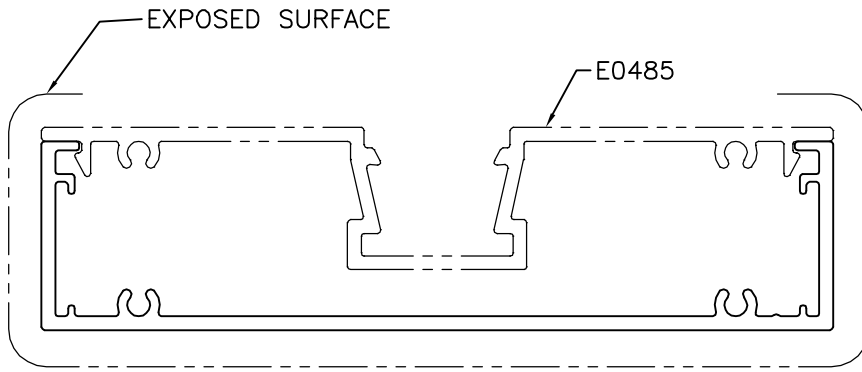

DETAIL OF "A"  
SCALE 3:1

P = PIP 0.3  
F = FULL RADIUS (8 PLACES)



SYMBOL OF QUALITY  
AN ISO 9002 COMPANY

**JINDAL ALUMINIUM LTD.**  
BANGALORE-560073 (INDIA)

	NAME	DATE
DRAWN	J.P.KAUSHIK	11-01-2016
CHECKED		
APPROVED	S.S. GARG	09-06-2016
SCALE		1:1
AREA mm <sup>2</sup>		310.878
PERIMETER mm.		361.24
WEIGHT kg/m		0.839
DRAWING No.	SECTION No.	
P-15494	-	
E0484	E0484	

1. ALL DIMENSIONS ARE IN mm.
2. ROUND OFF ALL SHARP CORNERS WITH 0.40 mm.
3. TOLERANCES WILL BE AS PER IS:3965-1981 UNLESS OTHERWISE SPECIFIED

PARTY'S NAME	H.V.ART N GLASS PVT. LTD., DELHI
PARTY'S DRAWING No.	AS PER DRAWING
ALLOY & TEMPER	6063 T6
DESCRIPTION	MISC. SECTION