

P-16048

E0516

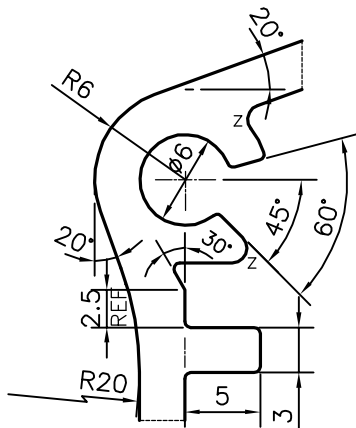

DETAIL OF "A"
SCALE 2:1

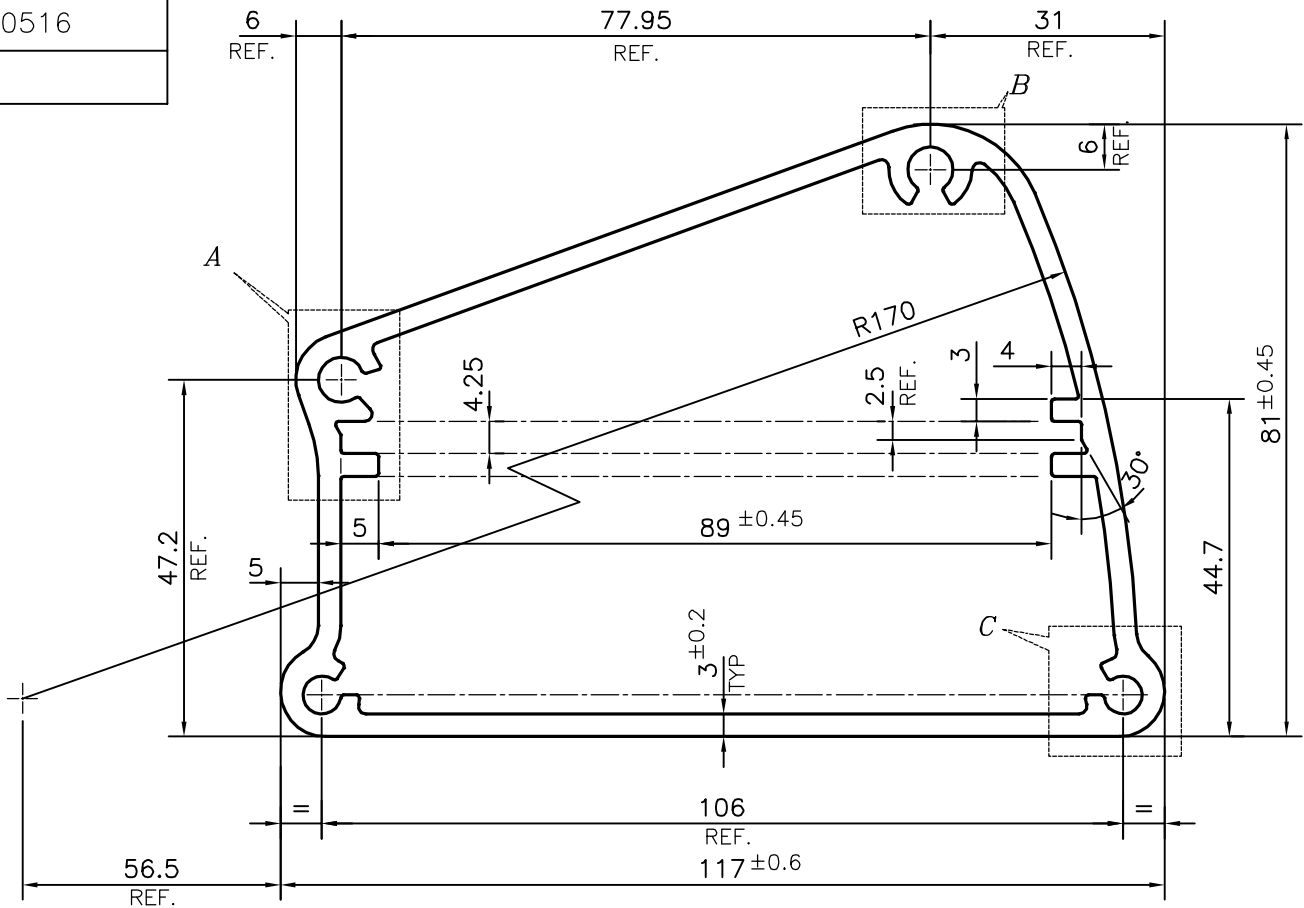
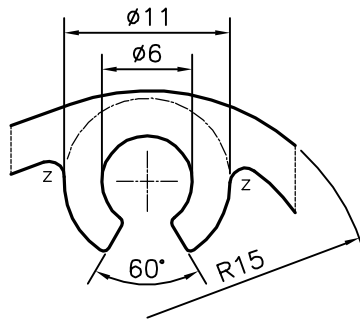

DETAIL OF "B"
SCALE 2:1

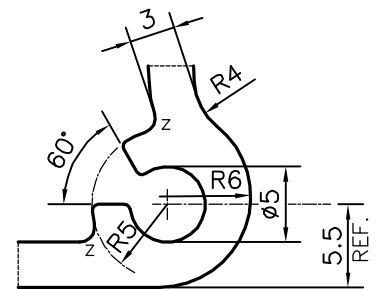

DETAIL OF "C"
SCALE 2:1

Z = RADIUS 1 mm. (6 PLACES)



SYMBOL OF QUALITY
AN ISO 9001 COMPANY

JINDAL ALUMINIUM LTD.
BANGALORE-560073 (INDIA)

	NAME	DATE
DRAWN	PARVESH	29-06-2016
CHECKED		
APPROVED	S.S. GARG	03-08-2016
SCALE		1:1
AREA mm ²		1152.169
PERIMETER mm.		345.934
WEIGHT kg/m		3.111
DRAWING No.	SECTION No.	
P-16048	-	
E0516	E0516	

- ALL DIMENSIONS ARE IN mm.
- ROUND OFF ALL SHARP CORNERS WITH 0.40 mm.
- TOLERANCES WILL BE AS PER BS:EN-12020-2 , UNLESS OTHERWISE SPECIFIED

PARTY'S NAME	BERKEL INDUSTRIES PVT. LTD., CHENNAI
PARTY'S DRAWING No.	AS PER AUTOCAD DRAWING-ES0001
ALLOY & TEMPER	6005 T6
DESCRIPTION	INDUSTRIAL SECTION