

P-15649

E0520

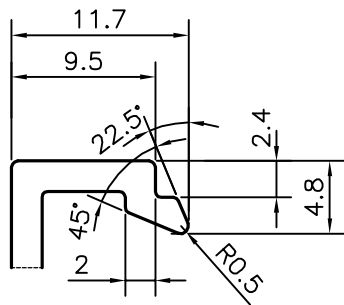

DETAIL OF "A"
SCALE 2:1

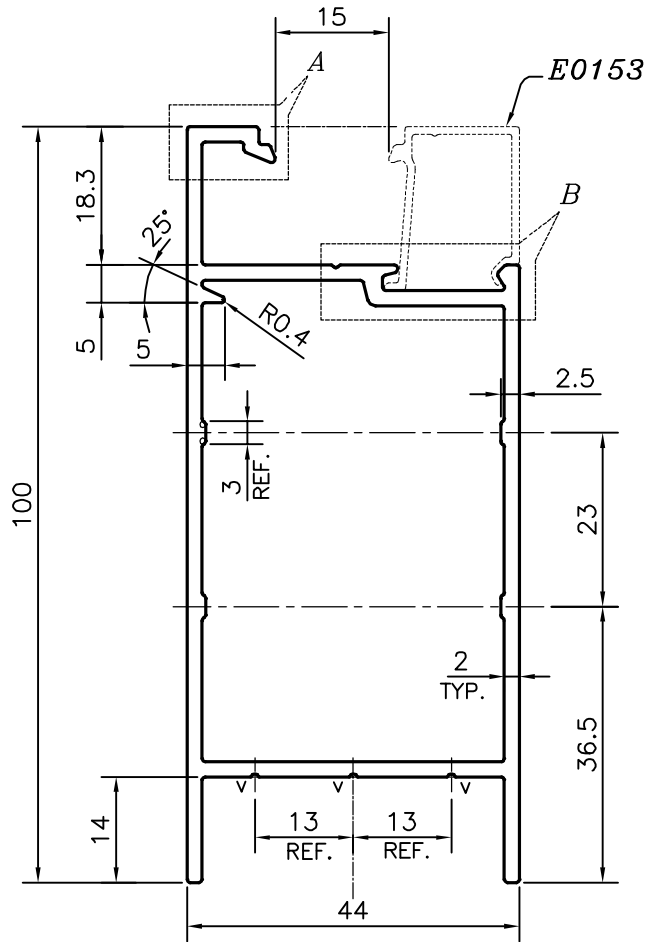
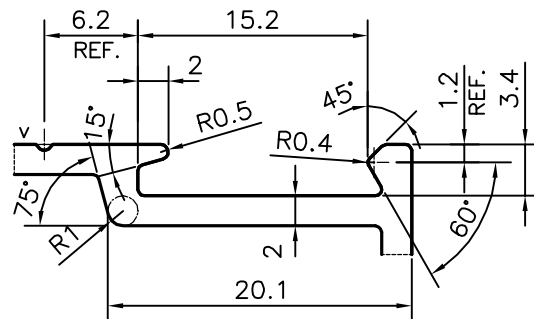

DETAIL OF "A"
SCALE 2:1

V = VEE GROOVE 0.4x90° (4 PLACES)



SYMBOL OF QUALITY
AN ISO 9001 COMPANY

JINDAL ALUMINIUM LTD.
BANGALORE-560073 (INDIA)

	NAME	DATE
DRAWN	PARVESH	08-03-2016
CHECKED		
APPROVED	S.S. GARG	08-08-2016
SCALE		1:1
AREA mm ²		565.849
PERIMETER mm.		347.902
WEIGHT kg/m		1.528
DRAWING No.	SECTION No.	
P-15649	-	
E0520	E0520	

1. ALL DIMENSIONS ARE IN mm.
2. ROUND OFF ALL SHARP CORNERS WITH 0.40 mm.
3. TOLERANCES WILL BE AS PER IS:6477-1983 , UNLESS OTHERWISE SPECIFIED

PARTY'S NAME	HV ART N GLASS, DELHI
PARTY'S DRAWING No.	AS PER REQUIREMENT
ALLOY & TEMPER	6063 T6
DESCRIPTION	ARCHITECTURAL SECTION