

P-15474

E0522

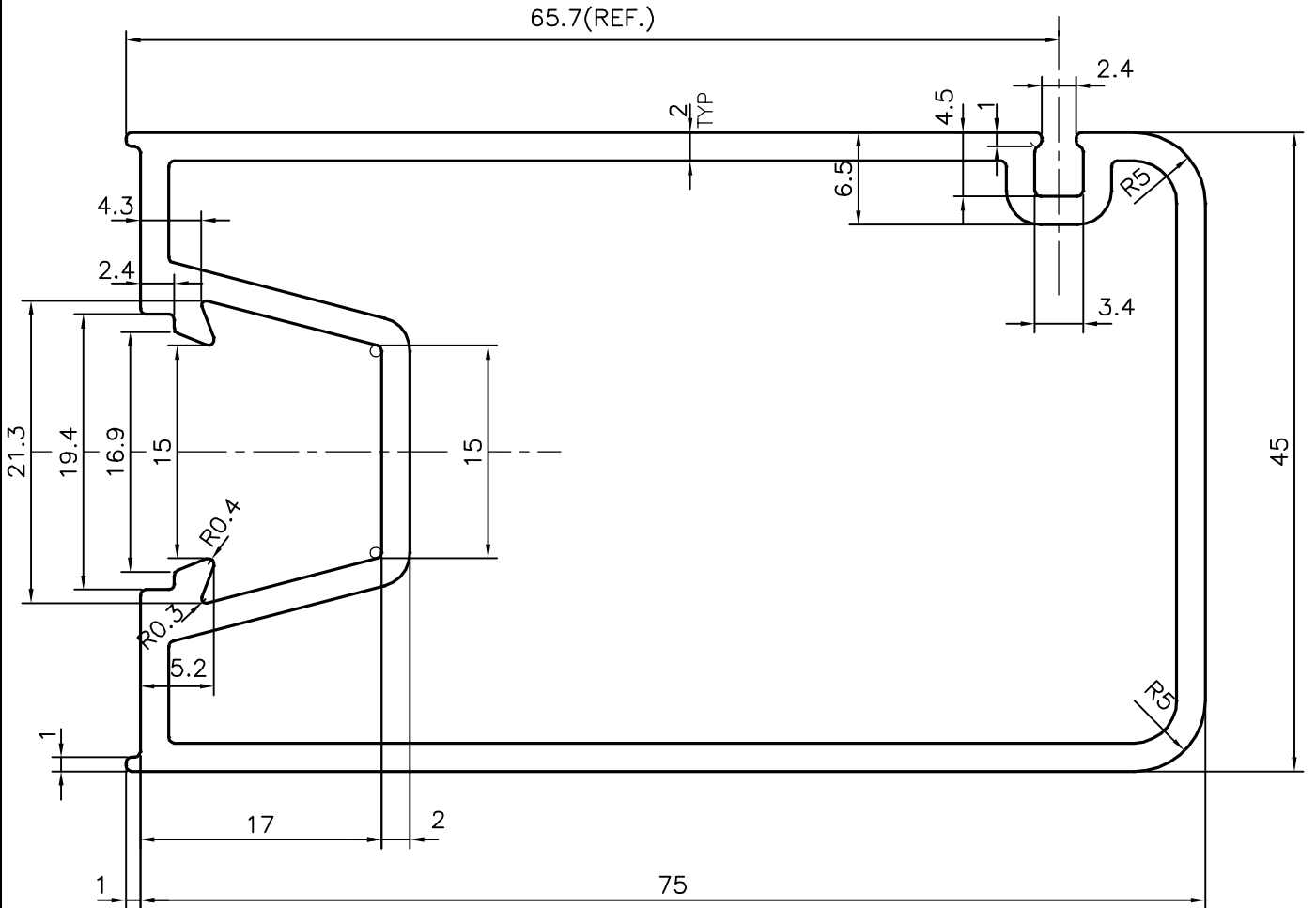
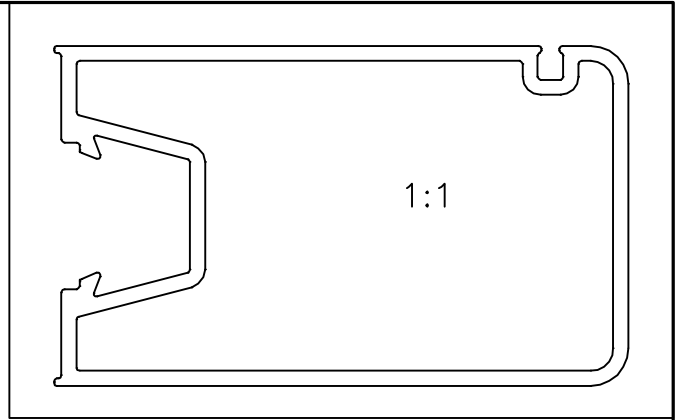

SYMBOL OF QUALITY  
AN ISO 9002 COMPANY

**JINDAL ALUMINIUM LTD.**  
BANGALORE-560073 (INDIA)

	NAME	DATE
DRAWN	J.P.KAUSHIK	02-01-2016
CHECKED		
APPROVED	S.S. GARG	08-08-2016
SCALE		2:1
AREA	mm <sup>2</sup>	549.775
PERIMETER	mm.	288.36
WEIGHT	kg/m	1.484
DRAWING No.	SECTION No.	
P-15474	-	
E0522	E0522	

1. ALL DIMENSIONS ARE IN mm.
2. ROUND OFF ALL SHARP CORNERS WITH 0.40 mm.
3. TOLERANCES WILL BE AS PER IS:6477-1983 UNLESS OTHERWISE SPECIFIED

PARTY'S NAME	H.V.ART N GLASS PVT. LTD., DELHI
PARTY'S DRAWING No.	AS PER SAMPLE
ALLOY & TEMPER	6063 T6
DESCRIPTION	MISC. SECTION