

P-16248

E0525

EXPOSED SURFACE

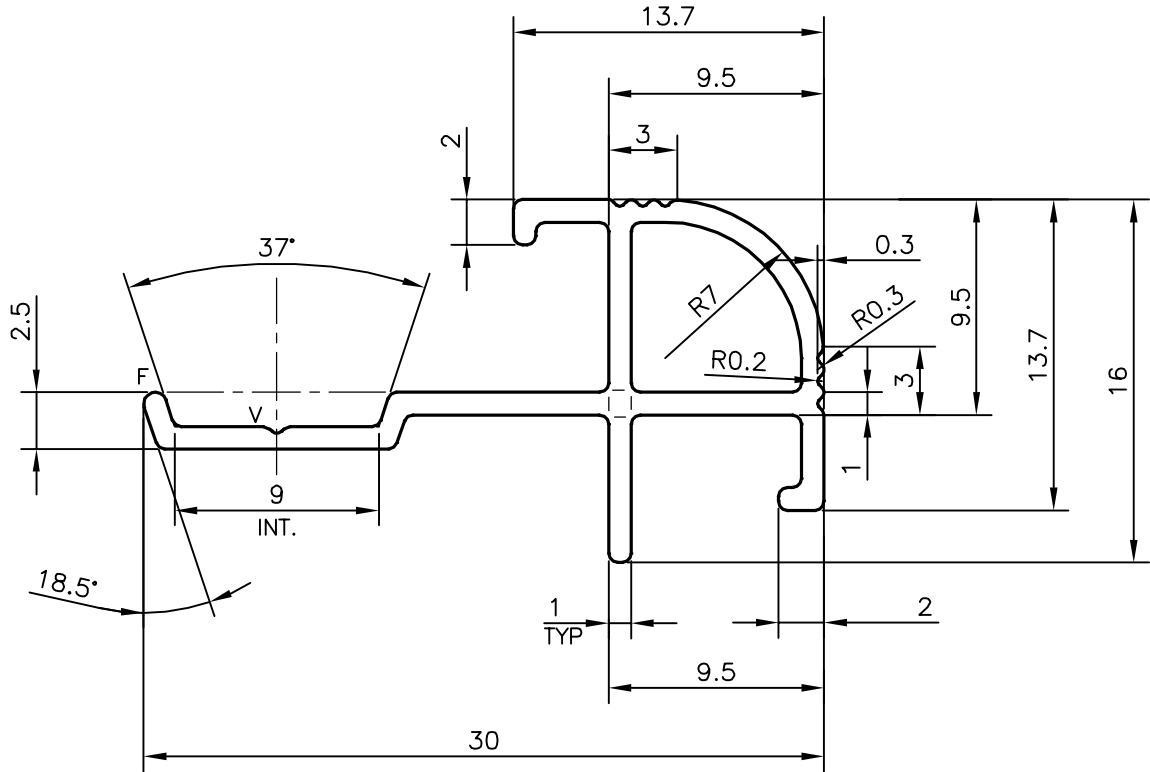
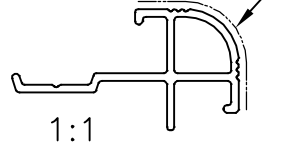

V = V GROOVE 0.3x90° (ONE PLACES)
 F = FULL RADIUS (ONE PLACES)



SYMBOL OF QUALITY
 AN ISO 9001 COMPANY

JINDAL ALUMINIUM LTD.
 BANGALORE-560073 (INDIA)

	NAME	DATE
DRAWN	J.P.KAUSHIK	22-08-2016
CHECKED		
APPROVED	S.S. GARG	27-08-2016

1. ALL DIMENSIONS ARE IN mm.
2. ROUND OFF ALL SHARP CORNERS WITH 0.40 mm.
3. TOLERANCES WILL BE AS PER IS:6477-1983 UNLESS OTHERWISE SPECIFIED

SCALE	3:1
AREA mm ²	69.723
PERIMETER mm.	112.069
WEIGHT kg/m	0.188

PARTY'S NAME	NIPANI INDUSTRIES, JABALPUR	DRAWING No.	SECTION No.
PARTY'S DRAWING No.	AS PER SAMPLE	P-16248	-
ALLOY & TEMPER	6063 T6	E0525	E0525
DESCRIPTION	MISC. SECTION		