

P-16551

E0556

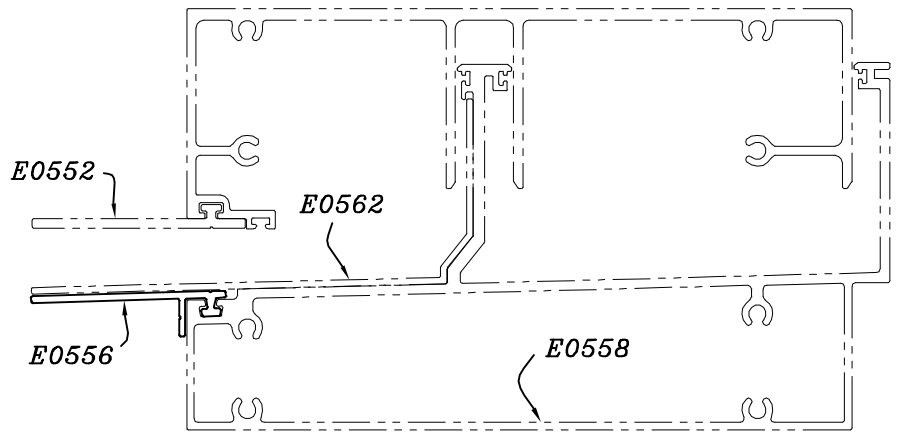

SCALE :- 0.5:1

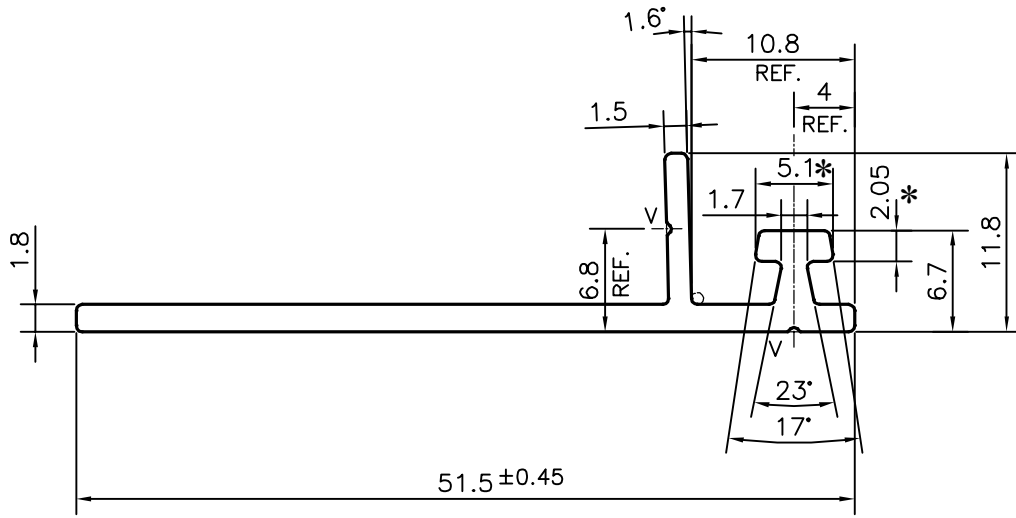

- 1. STRAIGHTNESS=1.0mm/M
- 2. TWIST=1.0mm/M
- 3. ANGULARITY= ±1°
- 4. FLATNESS =0.007xWIDTH

V = VEE GROOVE 0.3x90° (2 PLACES)
 * = CRITICAL DIMENSIONS

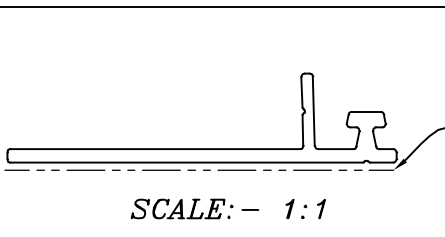

SCALE:- 1:1

UNSPECIFIED CORNERS RADIUS WILL BE 0.40 mm.

 SYMBOL OF QUALITY AN ISO 9001 COMPANY	JINDAL ALUMINIUM LTD. BANGALORE-560073 (INDIA)	NAME	DATE
		DRAWN	PARVESH 29-11-2016
		CHECKED	
		APPROVED	B. NATARAJA 03-11-2016
		SCALE	2:1
		AREA mm ²	123.33
		PERIMETER mm.	139.809
		WEIGHT kg/m	0.333
PARTY'S NAME	ALUFIT (INDIA) PRIVATE LIMITED, BANGALORE	DRAWING No.	SECTION No.
PARTY'S DRAWING No.	AS PER AUTOCAD DRAWING-AF-119(G2H)	P-16551	-
ALLOY & TEMPER	6063 T6	E0556	E0556
DESCRIPTION	CURTAIN WALL SECTION-HEAD EDGE GUARD		