

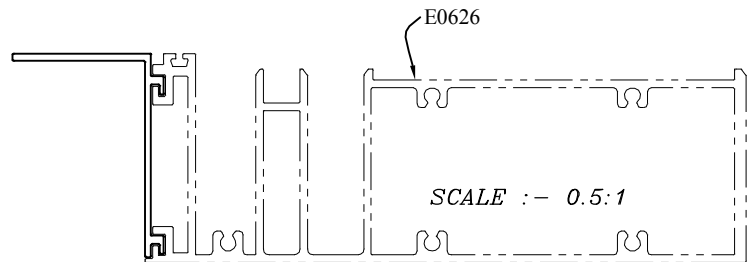

P-16949

E0627

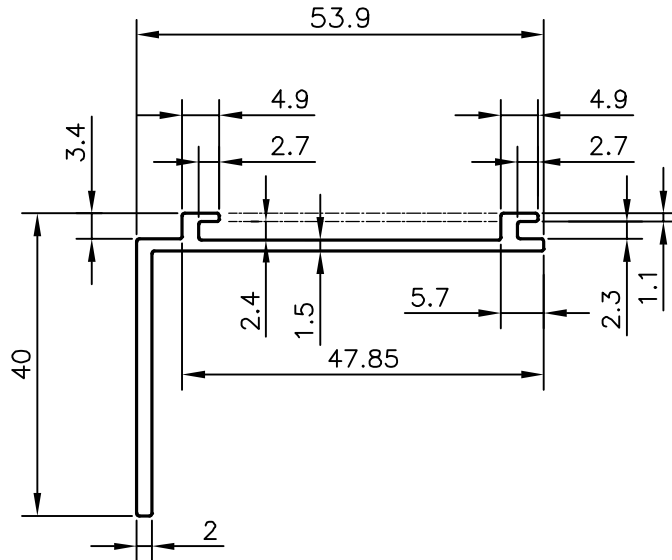

1. STRAIGHTNESS=1.0mm/M
2. TWIST=1.0mm/M
3. ANGULARITY= $\pm 1^\circ$
4. FLATNESS =0.007xWIDTH

ROUND OFF ALL SHARP CORNERS WITH 0.30 mm.

| | | | |
|---|--|----------------------|-----------------------|
|  SYMBOL OF QUALITY AN ISO 9001 COMPANY | JINDAL ALUMINIUM LTD. BANGALORE-560073 (INDIA) | NAME | DATE |
| | | DRAWN | PARVESH 01-04-2017 |
| | | CHECKED | |
| | | APPROVED | B.NATARAJA 08-04-2017 |
| | | SCALE | 1:1 |
| | | AREA mm ² | 173.068 |
| | | PERIMETER mm. | 203.282 |
| | | WEIGHT kg/m | 0.467 |
| PARTY'S NAME | ALUFIT (INDIA) PRIVATE LIMITED, BANGALORE | DRAWING No. | SECTION No. |
| PARTY'S DRAWING No. | AS PER AUTOCAD DRAWING-(ICC)-AL-13 | P-16949 | - |
| ALLOY & TEMPER | 6063 T6 | E0627 | E0627 |
| DESCRIPTION | CURTAIN WALL SECTION-CILL TRANSOM EDGE GUARD | | |