

P-16953

E0631

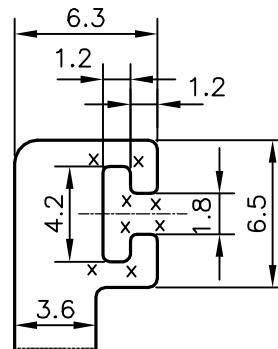
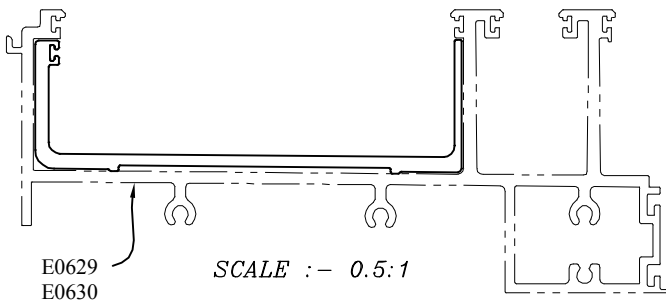
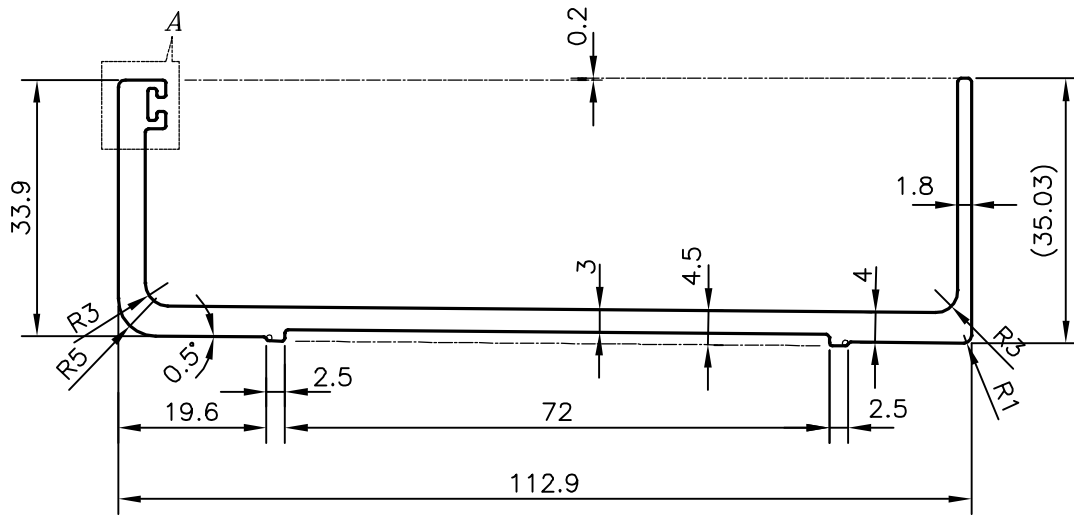

DETAIL OF "A"
SCALE 3:1

1. STRAIGHTNESS=1.0mm/M
2. TWIST=1.0mm/M
3. ANGULARITY= ±1°
4. FLATNESS =0.007xWIDTH

X = RADIUS 0.3 mm. (8 PLACES)



SYMBOL OF QUALITY
AN ISO 9001 COMPANY

JINDAL ALUMINIUM LTD.
BANGALORE-560073 (INDIA)

	NAME	DATE
DRAWN	PARVESH	01-04-2017
CHECKED		
APPROVED	B.NATARAJA	08-04-2017
SCALE		1:1
AREA mm ²		553.906
PERIMETER mm.		365.915
WEIGHT kg/m		1.496
DRAWING No.	SECTION No.	
P-16953	-	
E0631	E0631	

1. ALL DIMENSIONS ARE IN mm.
2. ROUND OFF ALL SHARP CORNERS WITH 0.40 mm.
3. TOLERANCES WILL BE AS PER IS:3965-1981, UNLESS OTHERWISE SPECIFIED

PARTY'S NAME	ALUFIT (INDIA) PRIVATE LIMITED, BANGALORE
PARTY'S DRAWING No.	AS PER AUTOCAD DRAWING-(ICC)-AL-14
ALLOY & TEMPER	6063 T6
DESCRIPTION	CURTAIN WALL SECTION-GUTTER PROFILE-01