

P-16963

E0637

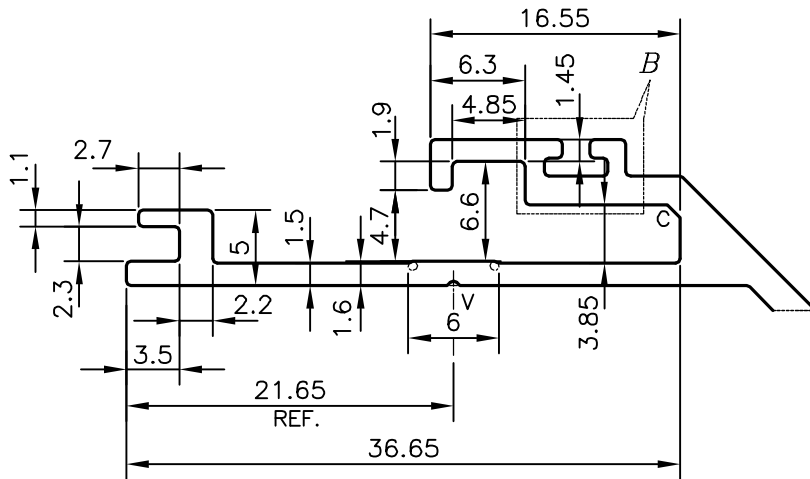

DETAIL OF "A"
SCALE 2:1

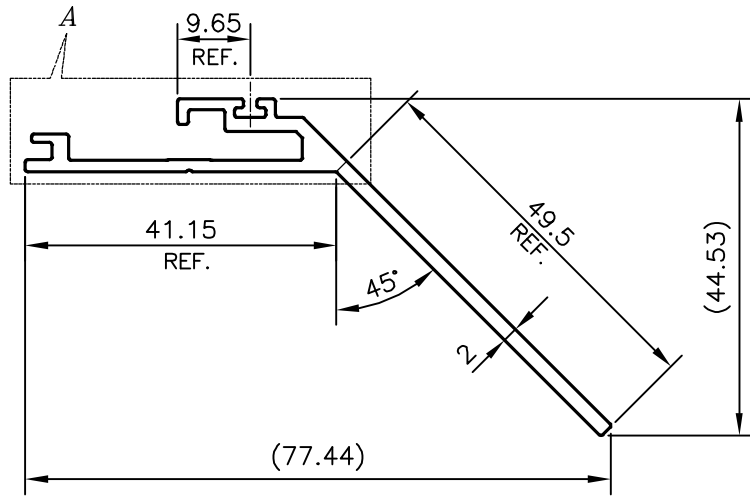
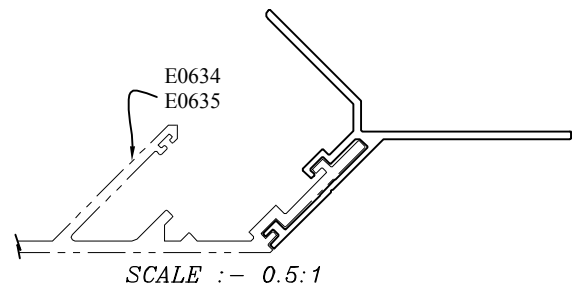
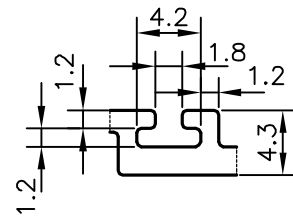

DETAIL OF "B"
SCALE 2:1

1. STRAIGHTNESS=1.0mm/M
2. TWIST=1.0mm/M
3. ANGULARITY= ±1°
4. FLATNESS =0.007xWIDTH

C = CHAMFER 0.85x90° (1 PLACE)
V = VEE GROOVE 0.3x90° (1 PLACE)

ROUND OFF ALL SHARP CORNERS WITH 0.30 mm.



SYMBOL OF QUALITY
AN ISO 9001 COMPANY

JINDAL ALUMINIUM LTD.
BANGALORE-560073 (INDIA)

	NAME	DATE
DRAWN	PARVESH	07-04-2017
CHECKED		
APPROVED	B.NATARAJA	12-04-2017
SCALE		1:1
AREA mm ²		230.647
PERIMETER mm.		254.343
WEIGHT kg/m		0.623
DRAWING No.	SECTION No.	
P-16963	-	
E0637	E0637	

1. ALL DIMENSIONS ARE IN mm.
2. ROUND OFF ALL SHARP CORNERS WITH 0.30 mm.
3. TOLERANCES WILL BE AS PER IS:3965-1981, UNLESS OTHERWISE SPECIFIED

PARTY'S NAME	ALUFIT (INDIA) PRIVATE LIMITED, BANGALORE
PARTY'S DRAWING No.	AS PER AUTOCAD DRAWING-(ICC)-AL-28
ALLOY & TEMPER	6063 T6
DESCRIPTION	CURTAIN WALL SECTION-EXTERNAL CORNER FEMALE MULLION EDGE GUARD-02