

P-16430

S5120

E0772

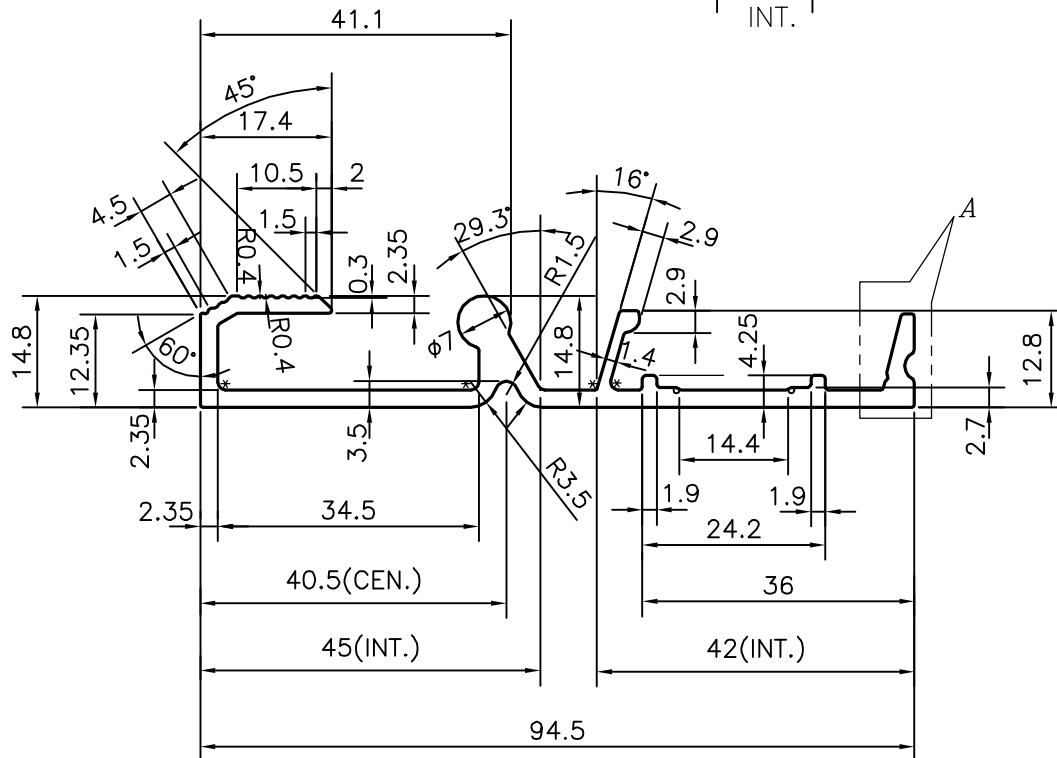
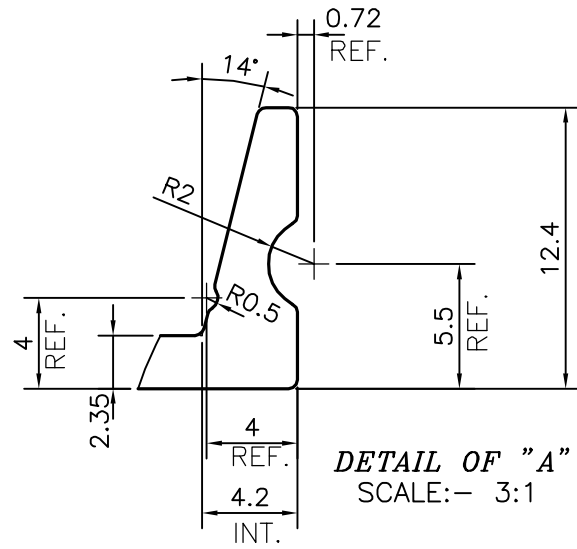

* = 1.0 RADIUS (4 PLACES)



SYMBOL OF QUALITY
AN ISO 9001 COMPANY

JINDAL ALUMINIUM LTD.
BANGALORE-560073 (INDIA)

	NAME	DATE
DRAWN	J.P.KAUSHIK	06-10-2016
CHECKED		
APPROVED	B.NATARAJ	21-10-2016
SCALE		1:1
AREA mm ²		398.576
PERIMETER mm.		317.917
WEIGHT kg/m		1.076
DRAWING No.	SECTION No.	
P-16430	-	
S5120	S5120	
E0772	E0772	

1. ALL DIMENSIONS ARE IN mm.
2. ROUND OFF ALL SHARP CORNERS WITH 0.40 mm.
3. TOLERANCES WILL BE AS PER,IS:3965-1981 UNLESS OTHERWISE SPECIFIED

PARTY'S NAME	MEGAVENT TECHNOLOGIES PVT LTD, BANGALORE
PARTY'S DRAWING No.	AS PER SAMPLE
ALLOY & TEMPER	6060 T6
DESCRIPTION	MISC. SECTION