

P-16432

S5122

E0774

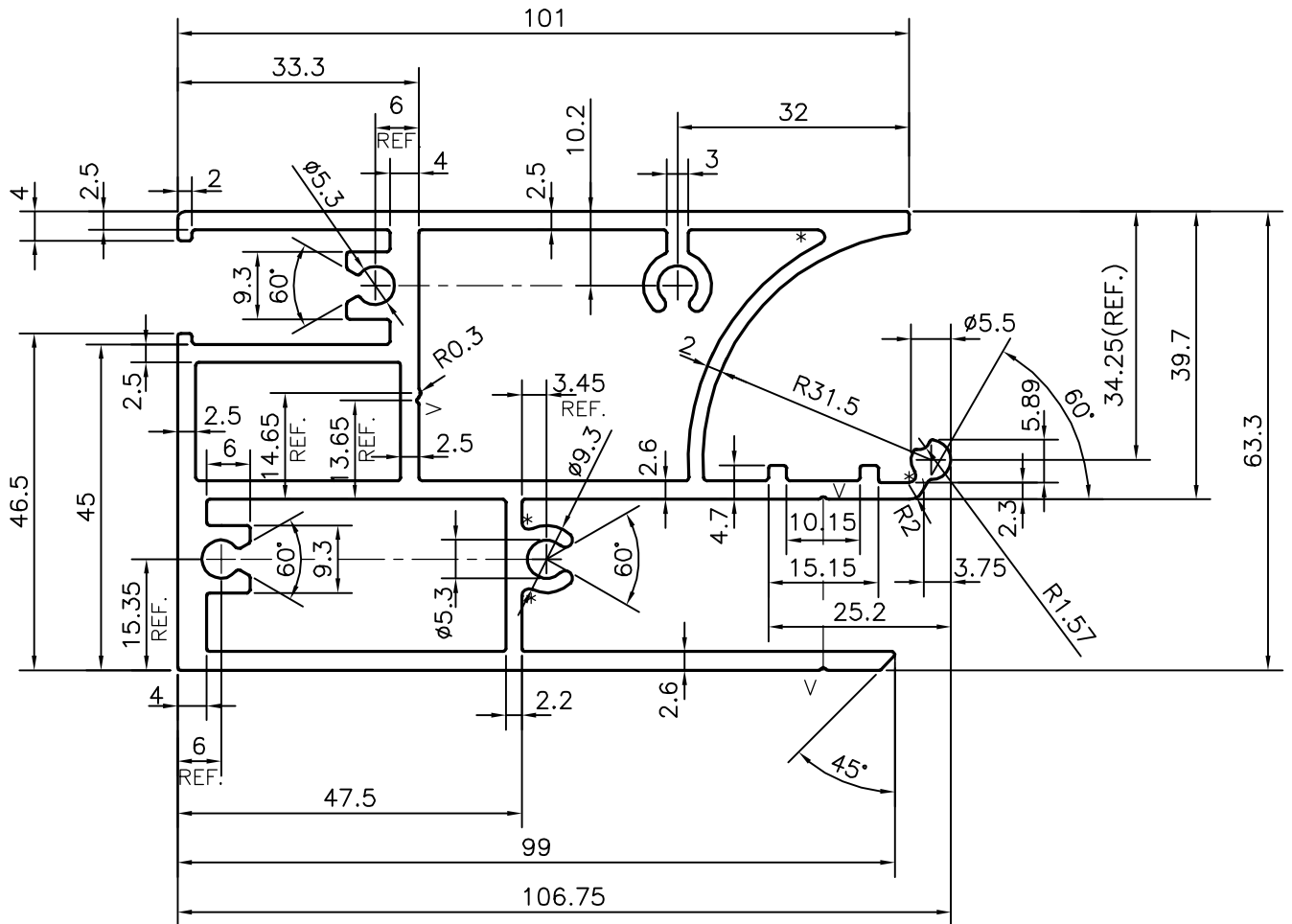
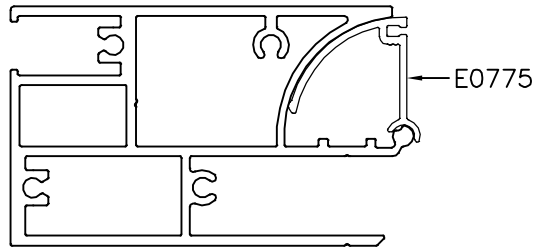

V = V GROOVE 0.4x90° (3 PLACES)
 * = 1.0 RADIUS (4 PLACES)



SYMBOL OF QUALITY
 AN ISO 9001 COMPANY

JINDAL ALUMINIUM LTD.
 BANGALORE-560073 (INDIA)

	NAME	DATE
DRAWN	J.P.KAUSHIK	07-10-2016
CHECKED		
APPROVED	B.NATARAJ	21-10-2016
SCALE		1:1
AREA mm ²		1405.718
PERIMETER mm.		609.92
WEIGHT kg/m		3.795
DRAWING No.	SECTION No.	
P-16432	-	
S5122	S5122	
E0774	E0774	

1. ALL DIMENSIONS ARE IN mm.
2. ROUND OFF ALL SHARP CORNERS WITH 0.40 mm.
3. TOLERANCES WILL BE AS PER,IS:6477-1983 UNLESS OTHERWISE SPECIFIED

PARTY'S NAME	MEGAVENT TECHNOLOGIES PVT LTD, BANGALORE
PARTY'S DRAWING No.	AS PER SAMPLE
ALLOY & TEMPER	6060 T6
DESCRIPTION	MISC. SECTION