

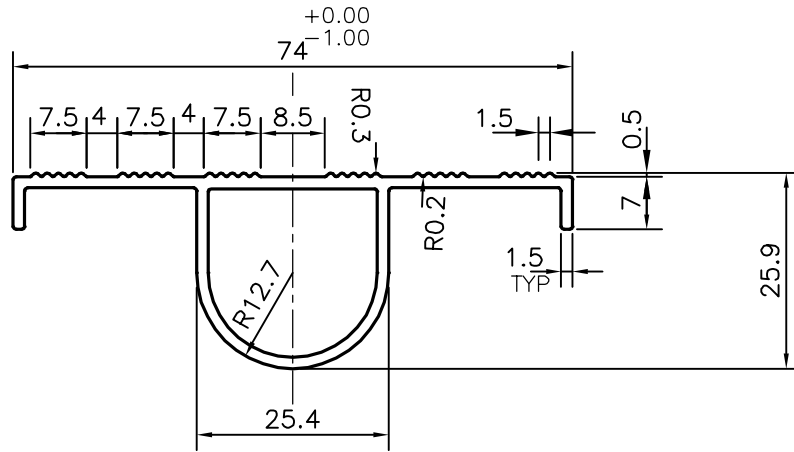

P-14602
X1870
22599
E0787

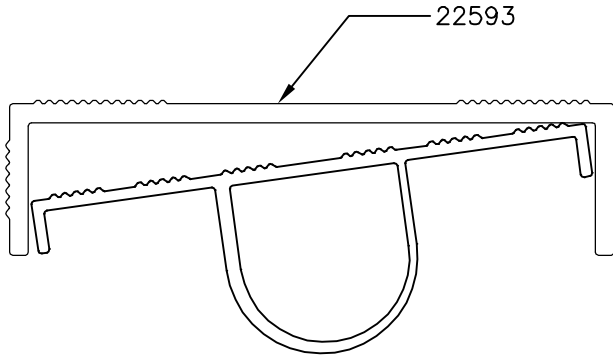

 SYMBOL OF QUALITY AN ISO 9001 COMPANY	<b>JINDAL ALUMINIUM LTD.</b> BANGALORE-560073 (INDIA)	NAME		DATE
		DRAWN	J.P.KAUSHIK	30-04-2015
1. ALL DIMENSIONS ARE IN mm. 2. ROUND OFF ALL SHARP CORNERS WITH 0.40 mm. 3. TOLERANCES WILL BE AS PER IS:6477-1983 UNLESS OTHERWISE SPECIFIED		CHECKED		
		APPROVED	S.S.GARG	02-05-2015
PARTY'S NAME		SCALE		1:1
		AREA mm <sup>2</sup>		231.425
PARTY'S DRAWING No.		PERIMETER mm.		218.614
		WEIGHT kg/m		0.625
ALLOY & TEMPER		DRAWING No.		SECTION No.
		HE9 WP		
DESCRIPTION		P-14602		-
		X1870		X1870
		22599		22599
		E0787		E0787