

P-17756

E0789

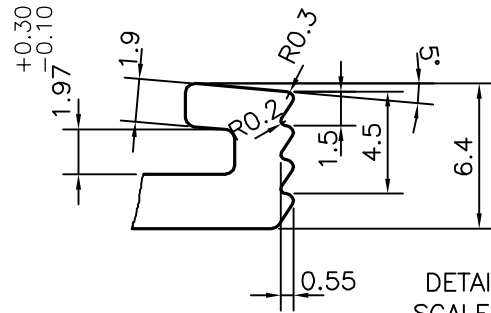

DETAIL "B"
SCALE 3:1

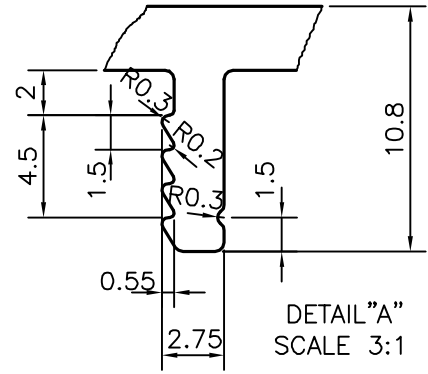

DETAIL "A"
SCALE 3:1

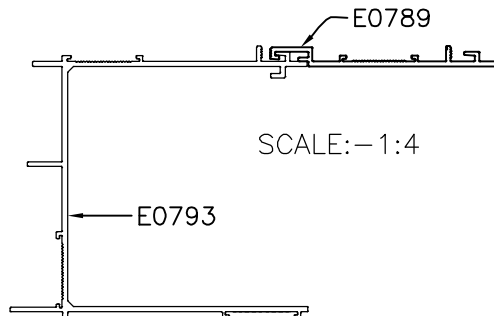
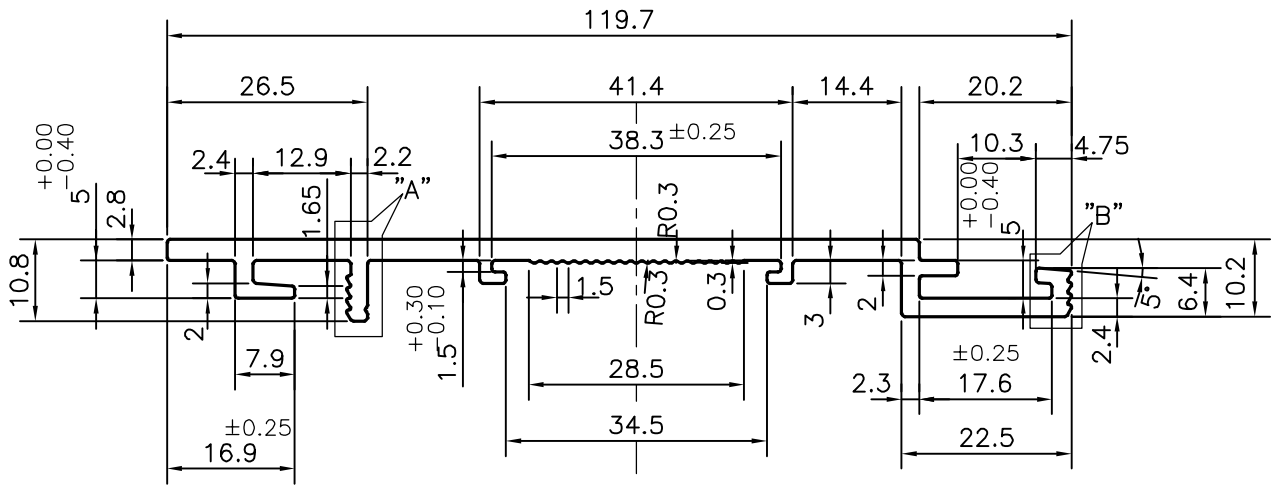

SYMBOL OF QUALITY
AN ISO 9001 COMPANY

JINDAL ALUMINIUM LTD.
BANGALORE-560073 (INDIA)

	NAME	DATE
DRAWN	J.P.KAUSHIK	06-01-2018
CHECKED		
APPROVED	B.NATARAJA	13-01-2018
SCALE		1:1
AREA	mm ²	427.017
PERIMETER	mm.	337.439
WEIGHT	kg/m	1.153
DRAWING No.	SECTION No.	
P-17756	-	
E0789	E0789	

1. ALL DIMENSIONS ARE IN mm.
2. ROUND OFF ALL SHARP CORNERS WITH 0.40 mm.
3. TOLERANCES WILL BE AS PER IS:3965-1981 , UNLESS OTHERWISE SPECIFIED

PARTY'S NAME	WAVE SUSPENSION SYSTEMS INDIA PVT. LTD., PUNE
PARTY'S DRAWING No.	AXPEP4H
ALLOY & TEMPER	6063 T6
DESCRIPTION	MISC. SECTION