

P-17757

E0790

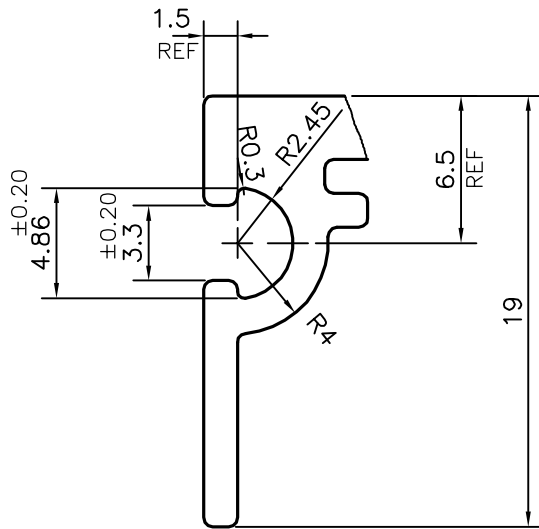

DETAIL "A"  
SCALE 3:1

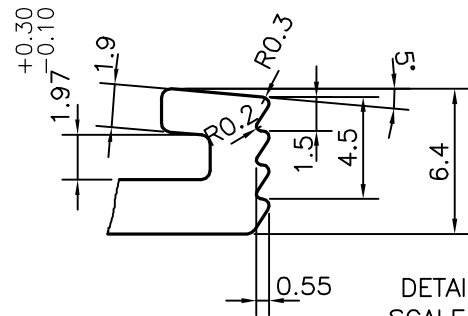

DETAIL "B"  
SCALE 3:1

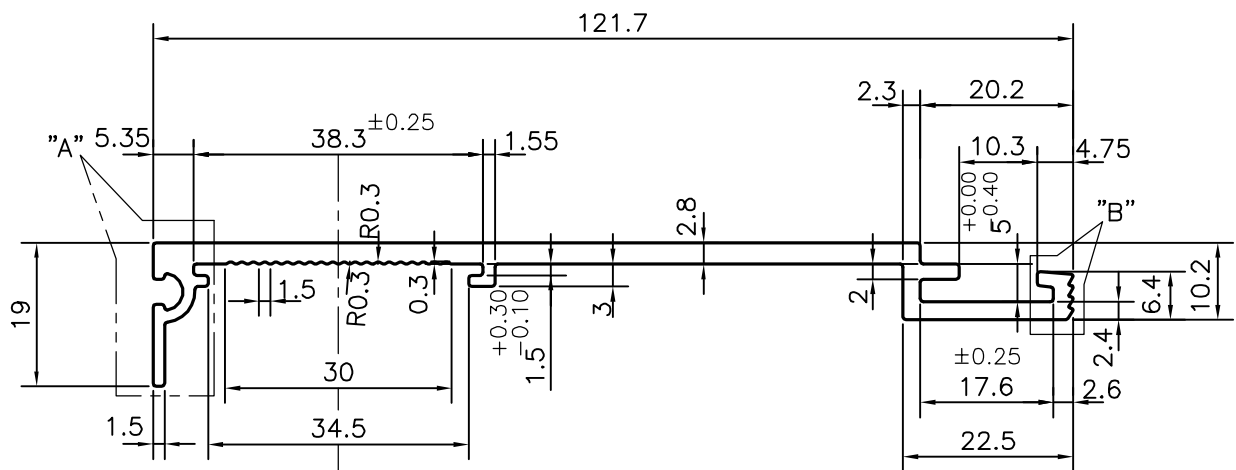

SYMBOL OF QUALITY  
AN ISO 9001 COMPANY

**JINDAL ALUMINIUM LTD.**  
BANGALORE-560073 (INDIA)

	NAME	DATE
DRAWN	J.P.KAUSHIK	06-01-2018
CHECKED		
APPROVED	B.NATARAJA	13-01-2018
SCALE		1:1
AREA	mm <sup>2</sup>	414.737
PERIMETER	mm.	336.995
WEIGHT	kg/m	1.120
DRAWING No.	SECTION No.	
P-17757	-	
E0790	E0790	

1. ALL DIMENSIONS ARE IN mm. 2. ROUND OFF ALL SHARP CORNERS WITH 0.40 mm. 3. TOLERANCES WILL BE AS PER IS:3965-1981 , UNLESS OTHERWISE SPECIFIED	
PARTY'S NAME	WAVE SUSPENSION SYSTEMS INDIA PVT. LTD., PUNE
PARTY'S DRAWING No.	AXPEP4
ALLOY & TEMPER	6063 T6
DESCRIPTION	MISC. SECTION