

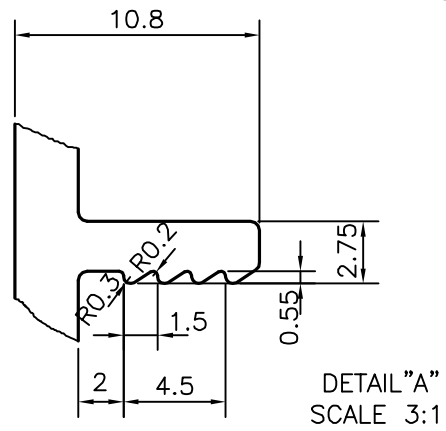

P-17761

E0793

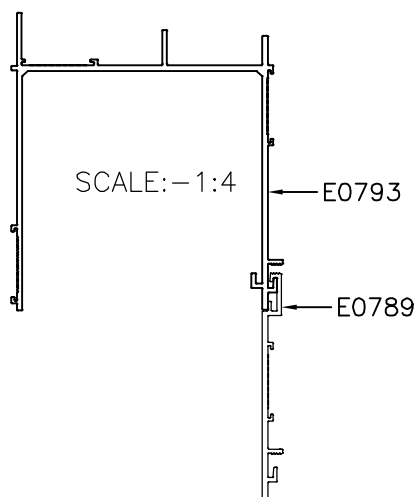
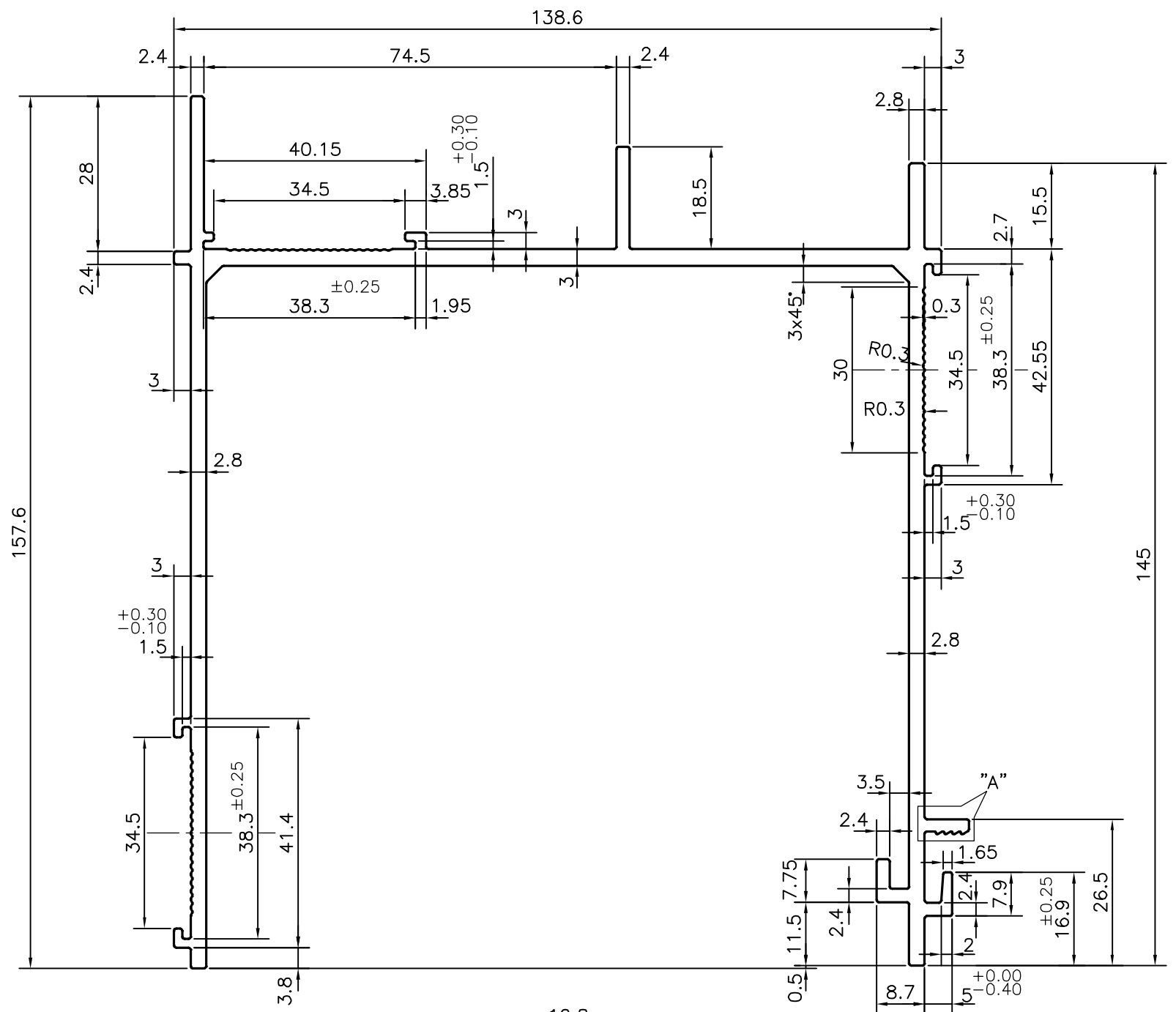

 SYMBOL OF QUALITY AN ISO 9001 COMPANY	JINDAL ALUMINIUM LTD. BANGALORE-560073 (INDIA)	NAME	DATE
		DRAWN	J.P.KAUSHIK 06-01-2018
1. ALL DIMENSIONS ARE IN mm. 2. ROUND OFF ALL SHARP CORNERS WITH 0.40 mm. 3. TOLERANCES WILL BE AS PER IS:3965-1981 UNLESS OTHERWISE SPECIFIED		CHECKED	
		APPROVED	B.NATARAJA 13-01-2018
PARTY'S NAME WAVE SUSPENSION SYSTEMS INDIA PVT. LTD., PUNE		SCALE	1:1
		AREA mm ²	1377.247
PARTY'S DRAWING No. AXP355C		PERIMETER mm.	1013.873
		WEIGHT kg/m	3.719
ALLOY & TEMPER 6063 T6		DRAWING No.	SECTION No.
		P-17761	-
DESCRIPTION MISC. SECTION		E0793	E0793