

P-17865

E0797

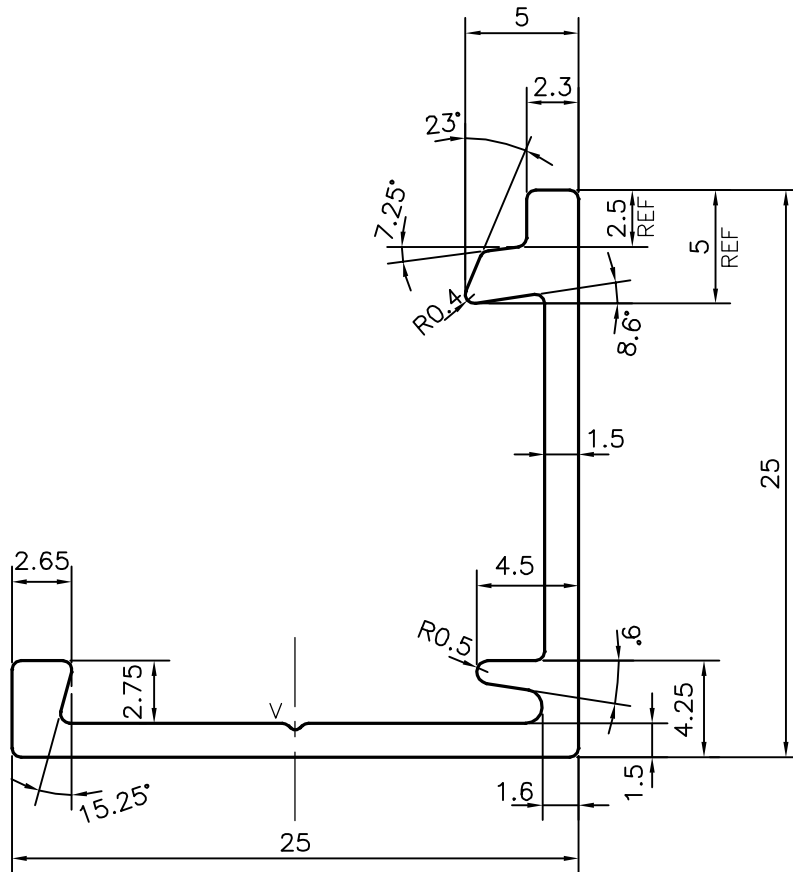

V = V GROOVE 0.30x90°(ONE PLACE)

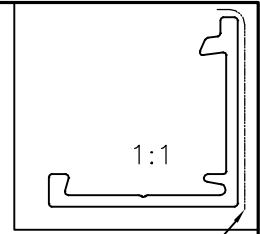
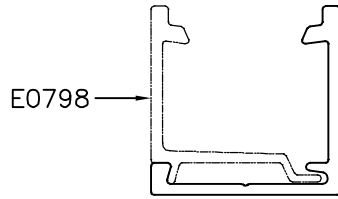

SYMBOL OF QUALITY
AN ISO 9001 COMPANY

JINDAL ALUMINIUM LTD.
BANGALORE-560073 (INDIA)

	NAME	DATE
DRAWN	J.P.KAUSHIK	13-02-2018
CHECKED		
APPROVED	B.NATARAJ	21-02-2018

1. ALL DIMENSIONS ARE IN mm.
2. ROUND OFF ALL SHARP CORNERS WITH 0.40 mm.
3. TOLERANCES WILL BE AS PER IS:3965-1981 , UNLESS OTHERWISE SPECIFIED

SCALE	3:1
AREA mm ²	91.843
PERIMETER mm.	115.435
WEIGHT kg/m	0.248

PARTY'S NAME SURFACES, BANGALORE

PARTY'S DRAWING No. AS PER DRAWING

ALLOY & TEMPER 6063 T6

DESCRIPTION MISC. SECTION

DRAWING No.	SECTION No.
P-17865	-
E0797	E0797