

P-17986

E0822

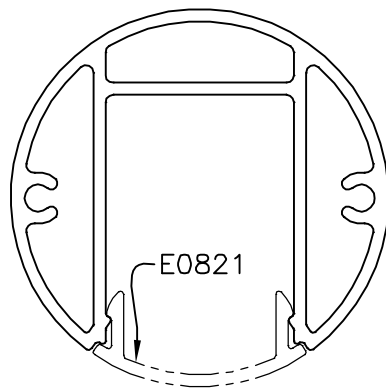

EXPOSED SURFACE

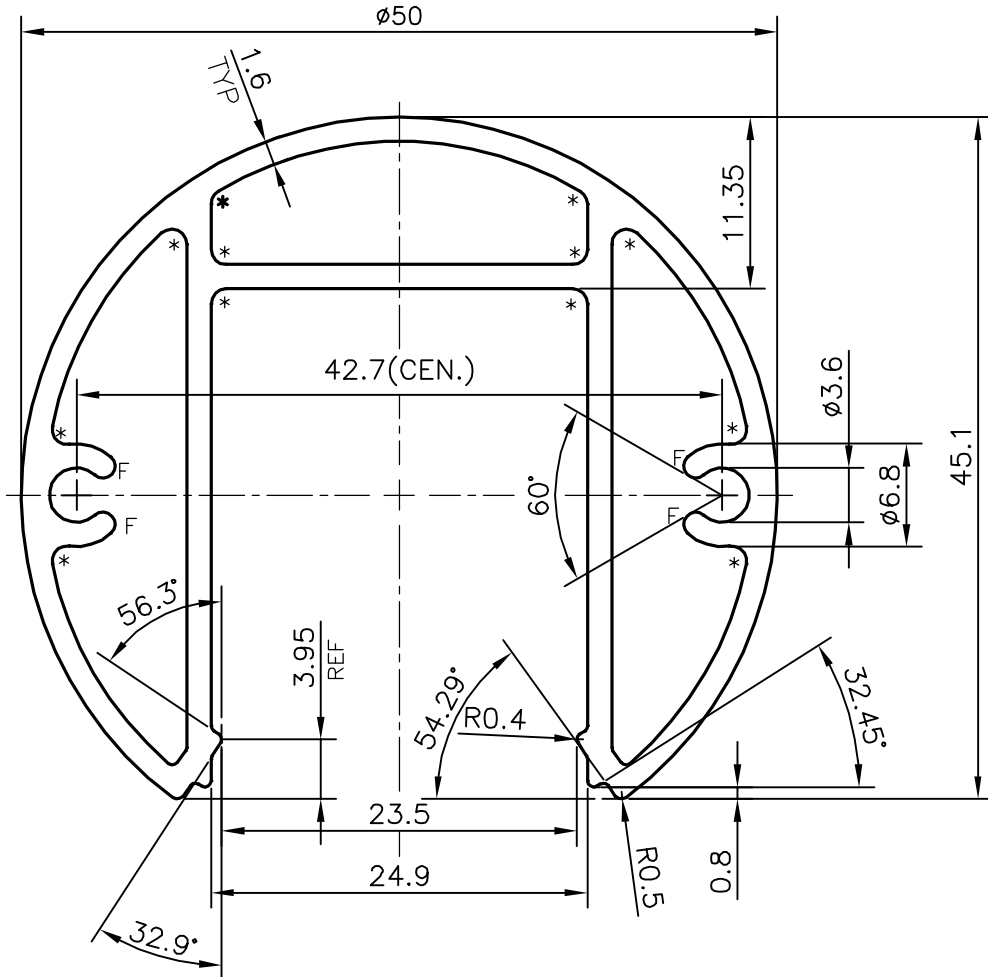
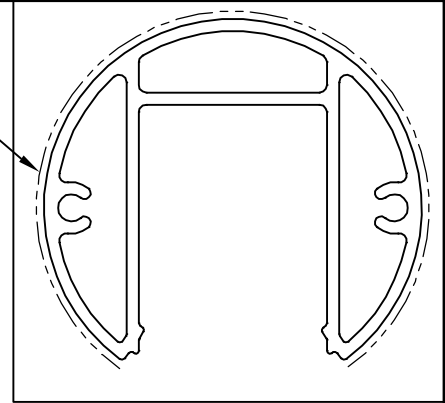

F = FULL RADIUS (4 PLACES)

* = 1.0 RADIUS (12 PLACES)

TOLERANCES ON OVERALL WIDTHS & WIDTHS ACROSS FLATS OF BARS, & REGULAR SECTIONS

| | | | |
|---------------------|----------------------|----------------------|---|
| UPTO 6.40mm - ±0.20 | UPTO 32.0mm - ±0.38 | UPTO 120.0mm - ±0.85 | 1. STRAIGHTNESS=1.0mm/M 2. TWIST=1.0mm/M 3. ANGULARITY= ±1° 4. FLATNESS =0.007xWIDTH |
| UPTO 10.0mm - ±0.23 | UPTO 50.0mm - ±0.46 | UPTO 160.0mm - ±1.02 | |
| UPTO 12.0mm - ±0.25 | UPTO 60.0mm - ±0.53 | UPTO 200.0mm - ±1.14 | |
| UPTO 16.0mm - ±0.28 | UPTO 80.0mm - ±0.69 | UPTO 250.0mm - ±1.40 | |
| UPTO 25.0mm - ±0.30 | UPTO 100.0mm - ±0.75 | UPTO 300.0mm - ±1.65 | |
| | | | |



SYMBOL OF QUALITY
AN ISO 9001 COMPANY

JINDAL ALUMINIUM LTD.
BANGALORE-560073 (INDIA)

| | | |
|----------|-------------|------------|
| | NAME | DATE |
| DRAWN | J.P.KAUSHIK | 14-03-2018 |
| CHECKED | | |
| APPROVED | B.NATARAJA | 30-03-2018 |

- ALL DIMENSIONS ARE IN mm.
- ROUND OFF ALL SHARP CORNERS WITH 0.40 mm.
- TOLERANCES WILL BE AS PER IS:6477-1983, UNLESS OTHERWISE SPECIFIED

| | |
|----------------------|---------|
| SCALE | 2:1 |
| AREA mm ² | 397.732 |
| PERIMETER mm. | 221.705 |
| WEIGHT kg/m | 1.074 |

| | |
|---------------------|---|
| PARTY'S NAME | ALUFIT (INDIA) PRIVATE LIMITED, BANGALORE |
| PARTY'S DRAWING No. | AL-SV-17 |
| ALLOY & TEMPER | 6063 T6 |
| DESCRIPTION | GUARD RAIL PIPE |

| | |
|-------------|-------------|
| DRAWING No. | SECTION No. |
| P-17986 | - |
| E0822 | E0822 |