

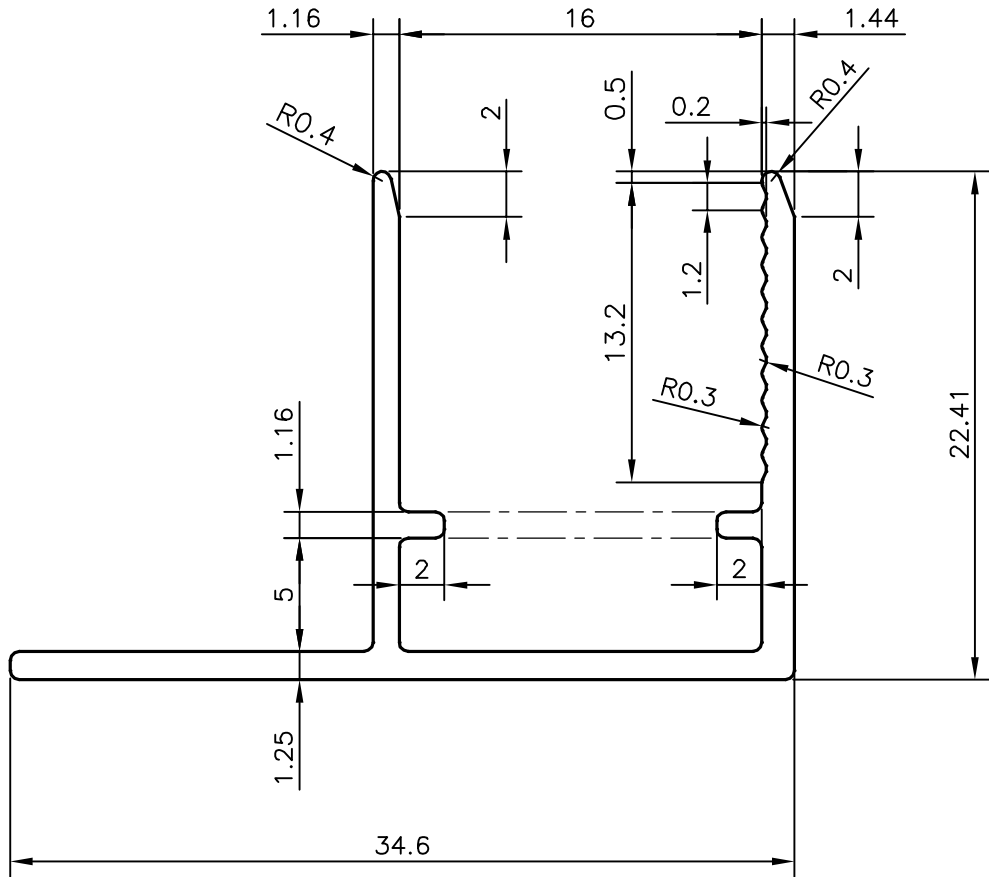

P-17879
X2302
E0843

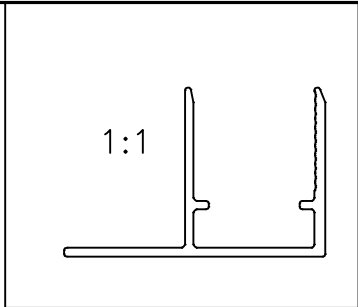

TOLERANCE CHART CD = CIRCUMSCRIBING CIRCLE

CD ≤ 100	100 < CD ≤ 200	200 < CD < 300	300 < CD < 500
UPTO 10mm - ±0.25	±0.30	±0.35	±0.40
10.0 - 25.0 - ±0.30	±0.40	±0.50	±0.60
25.0 - 50.0 - ±0.50	±0.60	±0.80	±0.90
50.0 - 100.0 - ±0.70	±0.90	±1.10	±1.30
100 - 150 - -	±1.10	±1.30	±1.50
150 - 200 - -	±1.3	±1.50	±1.80
200 - 300 - -	-	±1.70	±2.10
300 - 450 - -	-	-	±2.80

 SYMBOL OF QUALITY AN ISO 9001 COMPANY	JINDAL ALUMINIUM LTD. BANGALORE-560073 (INDIA)	DRAWN	J.P.KAUSHIK	DATE	16-02-2018
		CHECKED			
1. ALL DIMENSIONS ARE IN mm. 2. ROUND OFF ALL SHARP CORNERS WITH 0.40 mm. 3. TOLERANCES WILL BE AS PER BS:EN-755-9 UNLESS OTHERWISE SPECIFIED		APPROVED	B.NATARAJ	DATE	21-02-2018
		SCALE			3:1
PARTY'S NAME CLEAR AMBER GROUP, UK		AREA	mm ²		100.28
		PERIMETER	mm.		161.22
PARTY'S DRAWING No. AS PER DRAWING		WEIGHT	kg/m		0.271
		DRAWING No.		SECTION No.	
ALLOY & TEMPER 6063 T6		P-17879			-
		X2302			X2302
DESCRIPTION 16mm F-SECTION		E0843			E0843