

P-17880

X2303

E0844

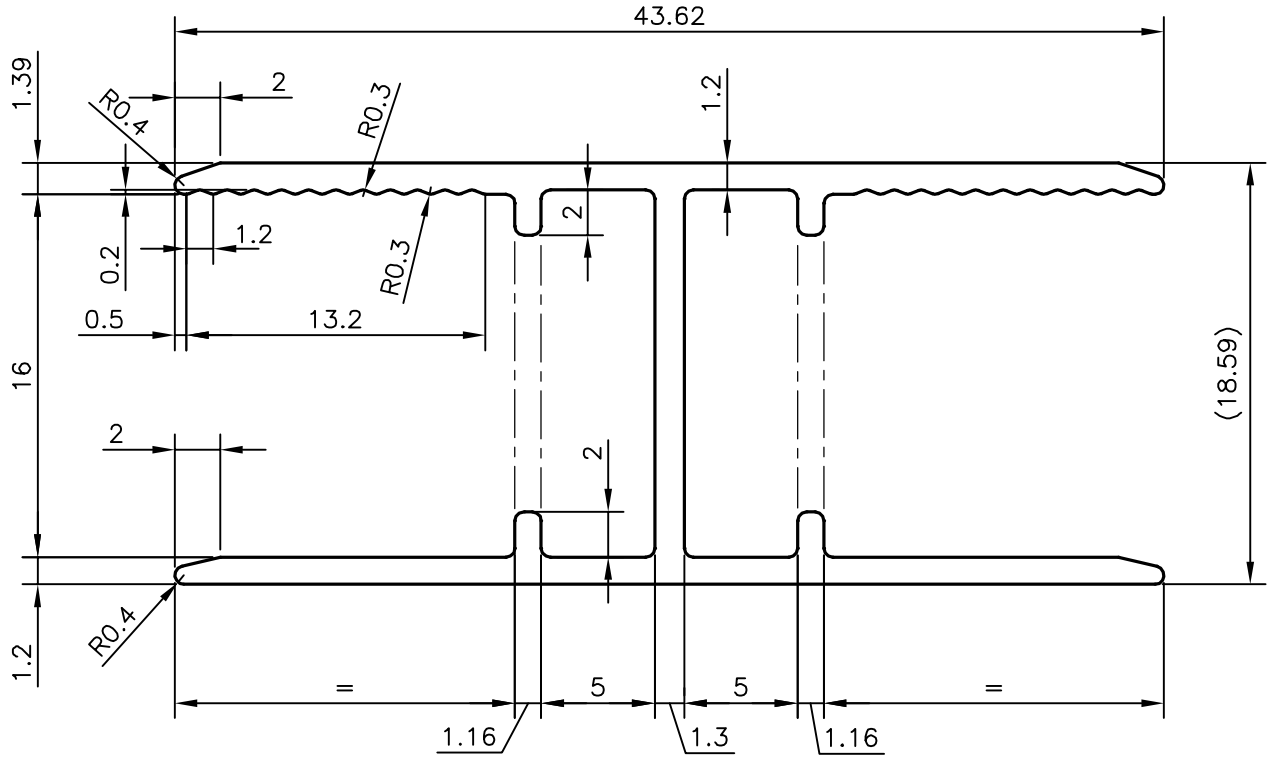
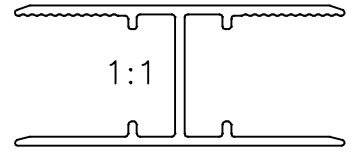

TOLERANCE CHART CD = CIRCUMSCRIBING CIRCLE

	CD ≤ 100	100 < CD ≤ 200	200 < CD < 300	300 < CD < 500
UPTO 10mm -	±0.25	±0.30	±0.35	±0.40
10.0 - 25.0 -	±0.30	±0.40	±0.50	±0.60
25.0 - 50.0 -	±0.50	±0.60	±0.80	±0.90
50.0 - 100.0 -	±0.70	±0.90	±1.10	±1.30
100 - 150 -	-	±1.10	±1.30	±1.50
150 - 200 -	-	±1.3	±1.50	±1.80
200 - 300 -	-	-	±1.70	±2.10
300 - 450 -	-	-	-	±2.80



SYMBOL OF QUALITY  
AN ISO 9001 COMPANY

**JINDAL ALUMINIUM LTD.**  
BANGALORE-560073 (INDIA)

	NAME	DATE
DRAWN	J.P.KAUSHIK	16-02-2018
CHECKED		
APPROVED	B.NATARAJ	21-02-2018

- ALL DIMENSIONS ARE IN mm.
- ROUND OFF ALL SHARP CORNERS WITH 0.40 mm.
- TOLERANCES WILL BE AS PER BS:EN-755-9 UNLESS OTHERWISE SPECIFIED

SCALE	3:1
AREA mm <sup>2</sup>	135.622
PERIMETER mm.	220.197
WEIGHT kg/m	0.366

PARTY'S NAME	CLEAR AMBER GROUP, UK
PARTY'S DRAWING No.	AS PER DRAWING
ALLOY & TEMPER	6063 T6
DESCRIPTION	16mm H-SECTION

DRAWING No.	SECTION No.
P-17880	-
X2303	X2303
E0844	E0844