

P-18446

E0882

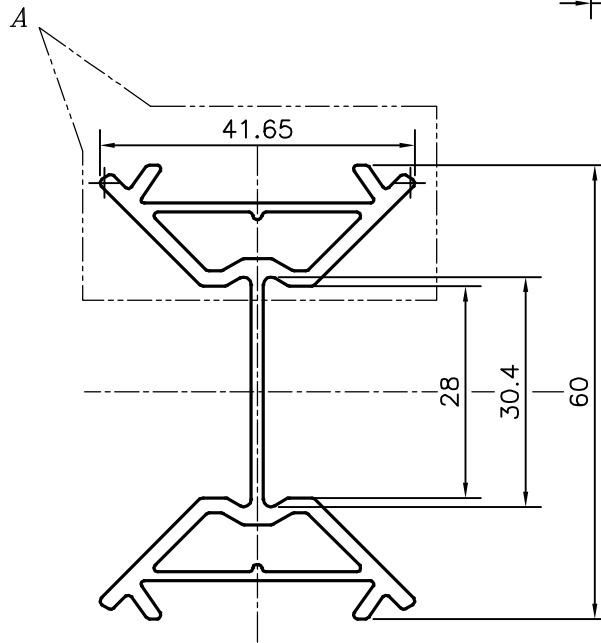
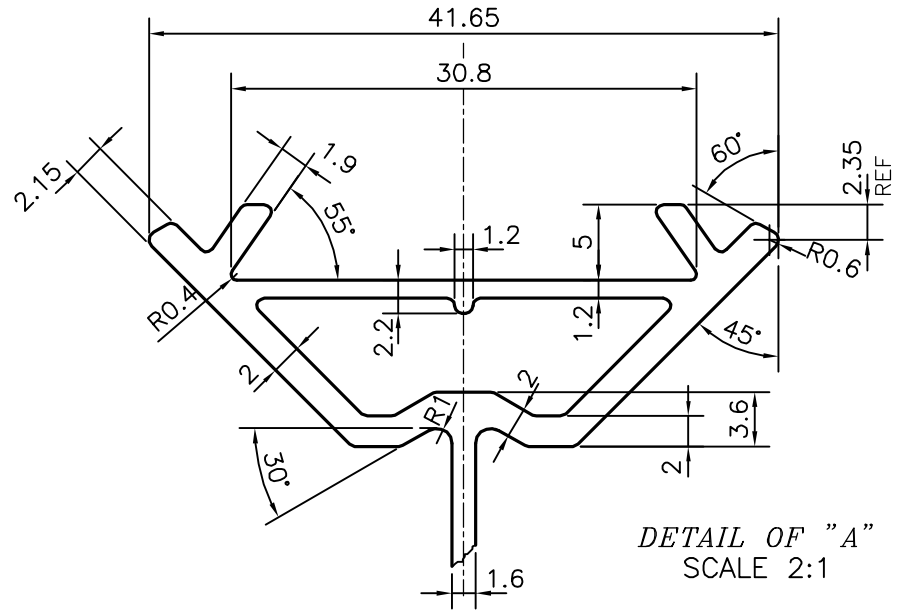

UNSPECIFIED RADIUS 0.5 mm

TOLERANCES ON OVERALL DIMENSIONS OF HOLLOW SECTIONS

UPTO 20.0mm - ±0.30	UPTO 80.0mm - ±0.70	UPTO 180.0mm - ±1.27	1. STRAIGHTNESS=1.7mm/M 2. TWIST=1.7mm/M 3. ANGULARITY= ±2° 4. FLATNESS =0.006xWIDTH
UPTO 30.0mm - ±0.38	UPTO 100.0mm - ±0.80	UPTO 200.0mm - ±1.40	
UPTO 40.0mm - ±0.45	UPTO 120.0mm - ±0.90	UPTO 225.0mm - ±1.52	
UPTO 50.0mm - ±0.52	UPTO 140.0mm - ±1.00		
UPTO 60.0mm - ±0.60	UPTO 160.0mm - ±1.14		



SYMBOL OF QUALITY  
AN ISO 9001 COMPANY

**JINDAL ALUMINIUM LTD.**  
BANGALORE-560073 (INDIA)

	NAME	DATE
DRAWN	J.P.KAUSHIK	11-07-2018
CHECKED		
APPROVED	B.NATARAJA	14-07-2018
SCALE		1:1
AREA mm <sup>2</sup>		378.18
PERIMETER mm.		290.255
WEIGHT kg/m		1.021
DRAWING No.	SECTION No.	
P-18446	-	
E0882	E0882	

- ALL DIMENSIONS ARE IN mm.
- ROUND OFF ALL SHARP CORNERS WITH 0.40 mm.
- TOLERANCES WILL BE AS PER IS:6477-1983 , UNLESS OTHERWISE SPECIFIED

PARTY'S NAME	SIEGER SPINTECH EQUIPMENT (P) LTD., COIMBATORE
PARTY'S DRAWING No.	MRTX200GIV7XX01A
ALLOY & TEMPER	HE9 WP
DESCRIPTION	CONVEYOR SECTION