

P-18477-2

E0930

ISSUE-2  
 MANDREL SIZE ADDED MANDREL SHAPE CHANGED  
 WEIGHT ALSO CHANGED FROM 1.130 TO 1.050 kg/m

ISSUE-3  
 DIMENSION CHANGED FROM 4.8 TO 4.6 mm  
 WEIGHT ALSO CHANGED FROM 1.050 TO 1.047 kg/m

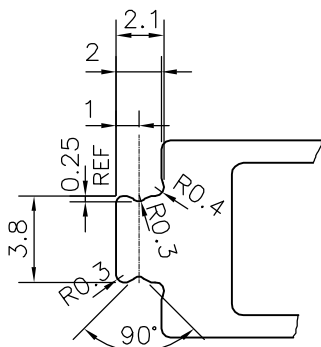
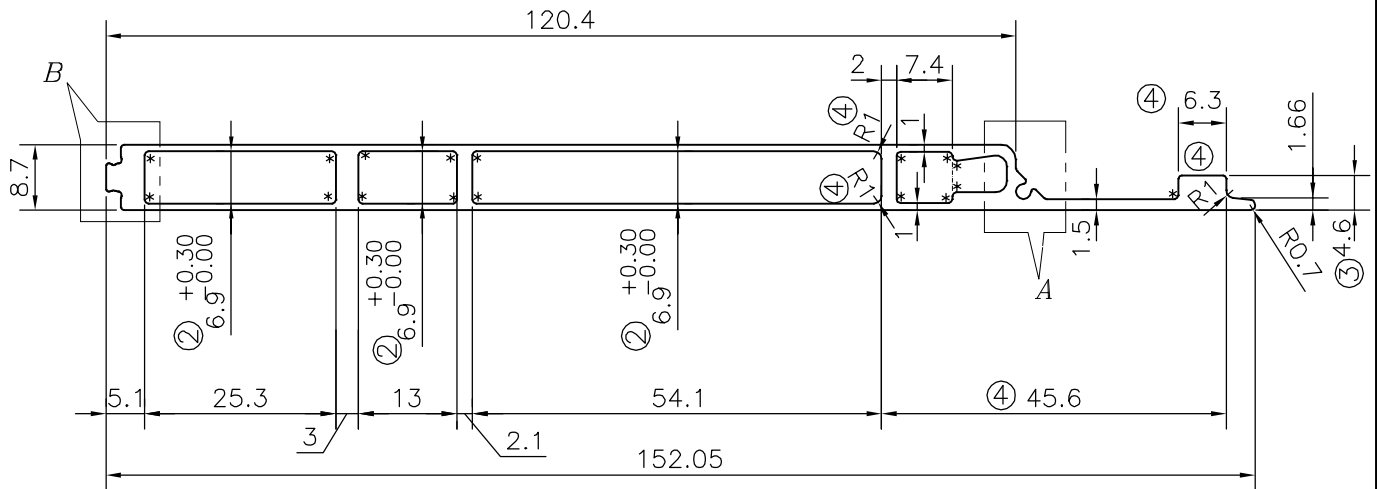

DETAIL OF "B"  
 SCALE 3:1

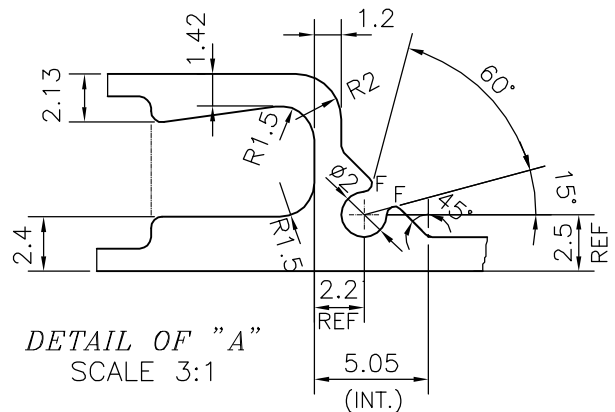

DETAIL OF "A"  
 SCALE 3:1  
 (INT.)

ISSUE-4

DIMENSION CHANGED FROM 6.0 TO 6.3 mm  
 RADIUS CHANGED FROM 0.5 mm TO 1.0 mm  
 DIMENSION ADDED 45.6  
 V GROOVE REMOVED  
 WEIGHT ALSO CHANGED FROM 1.047 TO 1.051 kg/m

F = FULL RADIUS (2 PLACES)  
 \* = 0.50 RADIUS (17 PLACES)  
 c = 1.0 RADIUS (4 PLACES)

TOLERANCES ON OVERALL DIMENSIONS OF HOLLOW SECTIONS

UPTO 20.0mm - ±0.30	UPTO 80.0mm - ±0.70	UPTO 180.0mm - ±1.27	1. STRAIGHTNESS=1.7mm/M 2. TWIST=1.7mm/M 3. ANGULARITY= ±2° 4. FLATNESS =0.006xWIDTH
UPTO 30.0mm - ±0.38	UPTO 100.0mm - ±0.80	UPTO 200.0mm - ±1.40	
UPTO 40.0mm - ±0.45	UPTO 120.0mm - ±0.90	UPTO 225.0mm - ±1.52	
UPTO 50.0mm - ±0.52	UPTO 140.0mm - ±1.00		
UPTO 60.0mm - ±0.60	UPTO 160.0mm - ±1.14		



SYMBOL OF QUALITY  
 AN ISO 9001 COMPANY

**JINDAL ALUMINIUM LTD.**  
 BANGALORE-560073 (INDIA)

	NAME	DATE
DRAWN	J.P.KAUSHIK	19-06-2019
CHECKED		
APPROVED	B.NATARAJA	25-06-2019
SCALE		1:1
AREA mm <sup>2</sup>		389.259
PERIMETER mm.		326.755
WEIGHT kg/m		1.051
DRAWING No.	SECTION No.	
P-18477-2	-	
E0930	E0930(ISSUE-4)	

- ALL DIMENSIONS ARE IN mm.
- ROUND OFF ALL SHARP CORNERS WITH 0.40 mm.
- TOLERANCES WILL BE AS PER IS:6477-1983, UNLESS OTHERWISE SPECIFIED

PARTY'S NAME	YAMUNA ENTERPRISES, AHMEDABAD
PARTY'S DRAWING No.	AS PER AutoCAD DRAWING
ALLOY & TEMPER	6063 T6
DESCRIPTION	TEXTILE SECTION