

P-17955

E0970

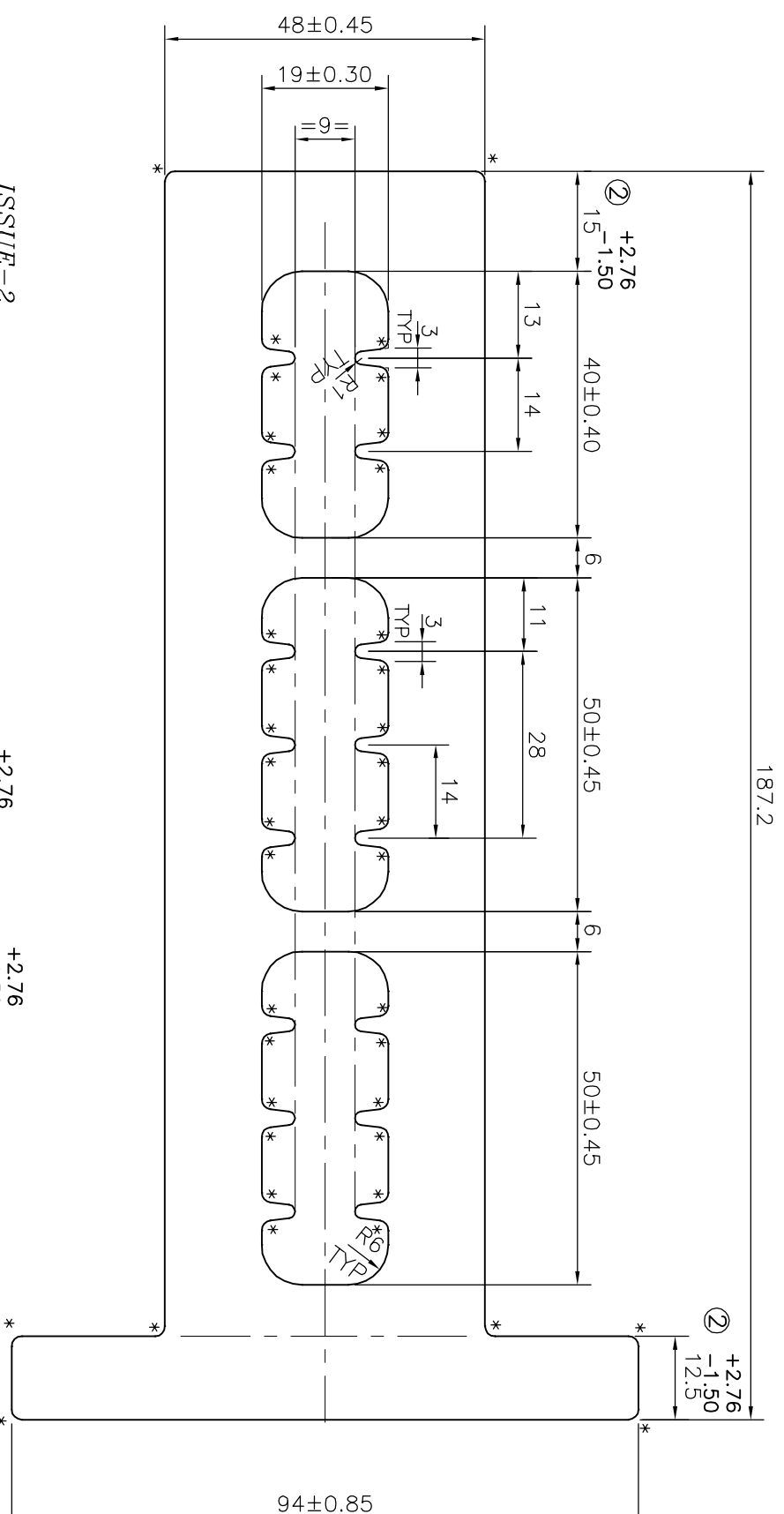

ISSUE-2
 TOLERANCE ADDED ON DIMENSIONS 15.0 mm & 12.5 mm

ANGULARITY = 2°
 FLATNESS = ±1.416
 EXTRUSION SHOULD BE FREE FROM DEFECTS

* = 1.5 RADIUS (40 PLACES)

| | | | |
|--|------------------------------------|--|--|
|  JINDAL ALUMINIUM LTD. BANGALORE-560073 (INDIA) | | SYMBOL OF QUALITY AN ISO 9001 COMPANY | NAME J.P. KAUSHIK DATE 17-11-2018 |
| 1. ALL DIMENSIONS ARE IN mm. 2. ROUND OFF ALL SHARP CORNERS WITH 0.40 mm. 3. TOLERANCES WILL BE AS PER IS:6477-1983 UNLESS OTHERWISE SPECIFIED | | SCALE 1:1 | CHECKED APPROVED B. NATARAJA 19-11-2018 |
| PARTY'S NAME | BHARAT ELECTRONICS LTD., GHAZIABAD | AREA mm ² | 7188.543 |
| PARTY'S DRAWING No. | 6105/A1 | PERIMETER mm. | 557.25 |
| ALLOY & TEMPER | 6063 T6 | WEIGHT kg/m | 19.409 |
| DESCRIPTION | COLD PLATE SECTION | DRAWING No. | P-17955 |
| | | SECTION No. | - |
| | | | E0970 |
| | | | E0970(ISSUE-2) |